

# Power Smoker II

**FOR LEAK ANALYSIS OF PLUMBING SYSTEMS**

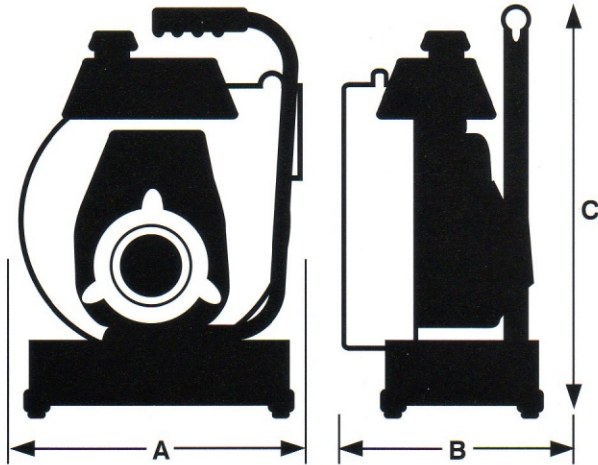

**Special Features:**

- 2.5 HP Honda GXH50 4 Stroke engine.
- Enclosed fan system capable of up to 700 cfm with adjustable inlet damper control to adjust cfm as necessary for the size of system.
- Utilizes LiquiSmoke™, a tested non-toxic, non-staining smoke fluid. LiquiSmoke™ pressure tank with in-line filter and quick disconnect. LiquiSmoke™ flow controlled by precision needle valve.
- 4" x 6' industrial flexible mining duct to connect to vent stack or clean out.
- High performance **SuperJet™** muffler. Continuous and constant smoke production. Nearly 100% burn - little to no wasted LiquiSmoke™ making it the most cost-effective smoke in the industry. See it work at our website.

**Physical Specifications** (See illustration above)

| Dimension         | PowerSmoker II |
|-------------------|----------------|
| A                 | 14.5"          |
| B                 | 15"            |
| C                 | 20"            |
| Weight            | 47 LBS.        |
| Gas Tank Capacity | 1.27 qts.      |



**HURCO**  
TECHNOLOGIES, INC.

Distributed by:



7401 First Place  
Cleveland, OH 44146  
1.800.362.0240