

ATTACHMENT CATALOGUE

SNOW PLOWS

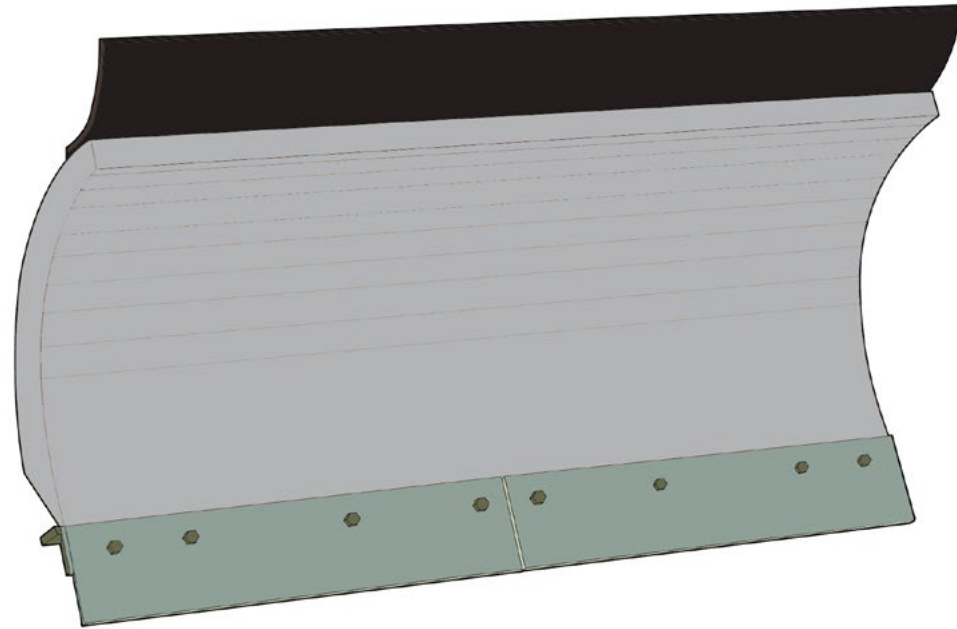

TRIP EDGE ANGLING SNOW PLOW

MADE IN CANADA

STANDARD FEATURES	AR 400 STEEL CUTTING EDGE - FLAT FACE COUPLINGS - RUBBER DEFLECTOR - HYDRAULIC ANGLING
AVAILABLE OPTIONS	EXTRA LIGHTS - WARNING FLAGS - CASTOR WHEELS - CURB WEAR BLOCK - <i>ADDITIONAL SIZES AVAILABLE</i>
AVAILABLE CUTTING EDGE OPTIONS	HARDOX - RUBBER - VULKOLLAN - CARBIDE - PU - CORRUNDUM - STAINLESS STEEL
TRACTOR REQUIREMENTS	CAT I CAT II (3-POINT HITCH) - 1 SET OF HYDRAULIC QUICK COUPLERS (DOUBLE ACTING)

MODEL	PAN-050-10	PAN-055-10	PAN-058-10	PAN-060-10
TOTAL WIDTH	50" (1270 mm)	55" (1397 mm)	58" (1473 mm)	60" (1524 mm)
STRAIGHT CLEARING WIDTH	50" (1270 mm)	55" (1397 mm)	58" (1473 mm)	60" (1524 mm)
ANGLED 30°	43" (1092 mm)	47" (1193 mm)	50" (1270 mm)	52" (1320 mm)
HEIGHT	36" (920 mm)			
MOULDBOARD HEIGHT	27" (680 mm)			
MOULDBOARD THICKNESS	11 GAUGE			
WEIGHT	525 lb (240 kg)	550 lb (250 kg)	564 lb (256 kg)	575 lb (261 kg)
NUMBER OF TRIP SECTIONS	2 x 30" (762 mm)			
POWER REQUIREMENTS	40 HP - 93 HP (30 kW - 70 kW)			
TRACTOR FIT (HOLDER)	C70 - C270	C70 - C270 - C992 - S75 - S100 - S130		

SNOW PLOWS

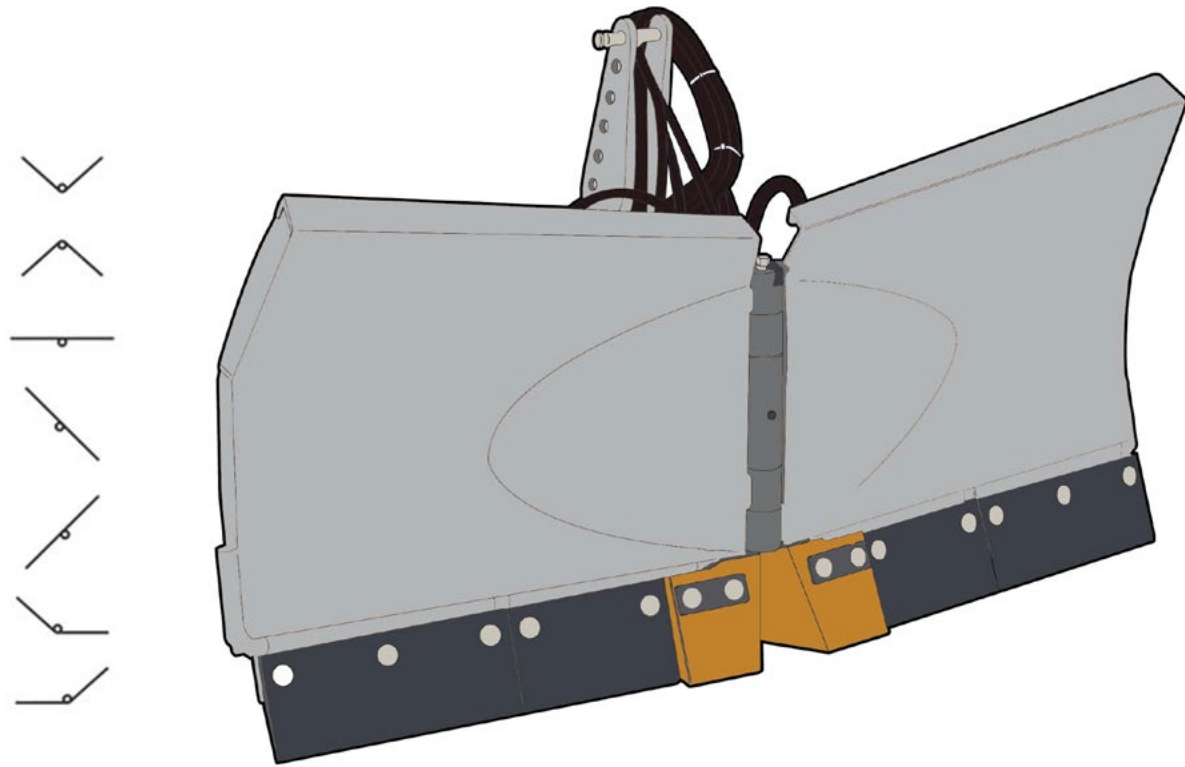

HYDRAULIC 5-WAY SNOW PLOW (FOLDING V-PLOW)

MADE IN CANADA

STANDARD FEATURES	HARDOX CUTTING EDGE - FLAT FACE HYDRAULIC COUPLINGS - POWDER COAT - HYDRAULIC ANGLING - SKID SHOE - 5 POSITIONS
AVAILABLE OPTIONS	EXTRA LIGHTS - WARNING FLAGS - CASTOR WHEELS - CURB WEAR BLOCK - <i>ADDITIONAL SIZES AVAILABLE</i>
AVAILABLE CUTTING EDGE OPTIONS	STAINLESS STEEL - RUBBER - VULKOLLAN - CARBIDE - PU - CORUNDUM - UHMW - MILD STEEL
TRACTOR REQUIREMENTS	CAT I CAT II (3-POINT HITCH) - 1 SET OF HYDRAULIC QUICK COUPLERS (DOUBLE ACTING)

MODEL	PFO-055-01	PFO-061-01	PFO-066-01	PFO-071-01
TOTAL WIDTH	55" (1400 mm)	61" (1520 mm)	66" (1680 mm)	70" (1780 mm)
STRAIGHT CLEARING WIDTH	55" (1400 mm)	61" (1520 mm)	66" (1680 mm)	70" (1780 mm)
ANGLED 30° ^ v	48" (1220 mm)	52" (1320 mm)	58" (1470 mm)	61" (1550 mm)
HEIGHT	33.5" (851 mm)			
MOULDBOARD HEIGHT	30" (762 mm)			
MOULDBOARD THICKNESS	11 GAUGE			
WEIGHT	519 lb (235 kg)	546 lb (248 kg)	573 lb (260 kg)	605 lb (275 kg)
POWER REQUIREMENTS	35 HP (26 kW)	40 HP (30 kW)		60 HP (45 kW)
TRACTOR FIT (HOLDER)	C70 - C270	C70 - C270 - C992 - S75 - S100 - S130		C992 - S75 - S100 - S130

SNOW PLOWS

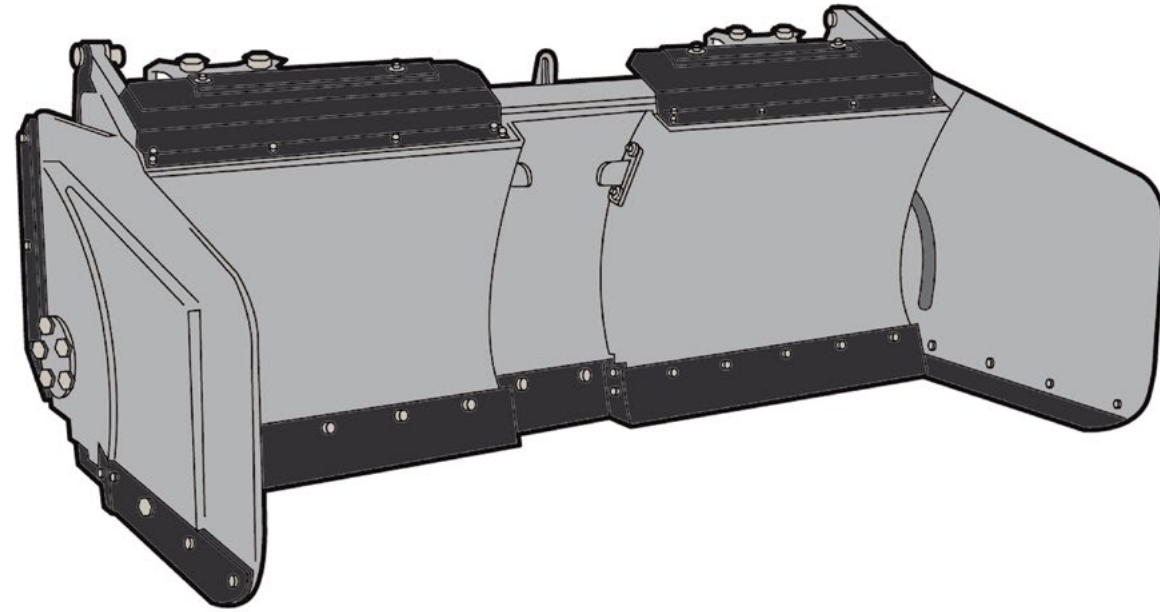

HYDRAULIC ANGLE PLOW (HYDRAULIC SNOW WINGS)

MADE IN CANADA

STANDARD FEATURES	CHT 400 STEEL STRUCTURE - TRIP MECHANISM - SLIDE ON TEFLON PLATE - 30° REVERSE CAPACITY
AVAILABLE OPTIONS	SOLENOID 12 VOLTS
TRACTOR REQUIREMENTS	WINTER TIRES - COUNTERWEIGHT

MODEL	WAP-610-10
CLEARING WIDTH CLOSED	65.5" (1663 mm)
CLEARING WIDTH OPEN	120.5" (3060 mm)
HEIGHT	28" (711 mm)
H.D. SNOW GATES	25" (635 mm)
WEIGHT	1405 lb (637 kg)
POWER REQUIREMENTS	70 HP (52 kW)
TRACTOR FIT (HOLDER)	C992 - S75 - S100 - S130

SNOW BLOWERS

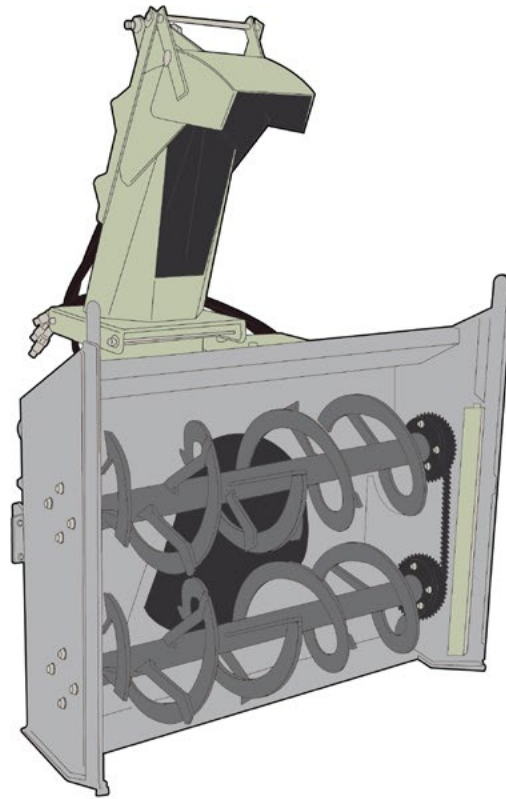

PTO DRIVEN BOX SNOW BLOWER - DUAL AUGER TYPE

MADE IN CANADA

STANDARD FEATURES	HQWRS CUTTING EDGES & SKID SHOES - ICE BREAKER AUGER TIPS - FLAT FACE COUPLINGS
AVAILABLE OPTIONS	60" (1524 mm) TRUCK LOADING CHUTE EXTENSION FOR ALL BBX SNOWBLOWERS (BCE-061-01) - <i>ADDITIONAL SIZES AVAILABLE</i>
TRACTOR REQUIREMENTS	CAT I CAT II (3-POINT HITCH) - 2 SETS OF HYDRAULIC QUICK COUPLERS (DOUBLE ACTING) - 1 3/8" - 6 SPLINE PTO SHAFT 540 RPM - COUNTERWEIGHT

MODEL	BBX-044-01	BBX-050-01	BBX-060-01
TOTAL WIDTH	44" (1120 mm)	50" (1270 mm)	60" (1524 mm)
CLEARING WIDTH	44" (1120 mm)	50" (1270 mm)	60" (1524 mm)
TOTAL HEIGHT	76" (1930 mm)		
HOUSING HEIGHT	39" (990 mm)		
WEIGHT	760 lb (344 kg)	880 lb (399 kg)	1095 lb (496 kg)
CHUTE	HYDRAULIC w/ HYDRAULIC FLAP		
CHUTE ROTATION	270°		
DRIVE ASSEMBLY	SIDE DRIVE VIA GEARBOX & CHAIN GEARBOX: 540 RPM & 1000 RPM		
OVERLOAD PROTECTION	SHEAR PINS		
CUTTING AUGER DIAMETER	15" (381 mm)		
IMPELLER DIAMETER	24" x 8" (609 mm x 203 mm)		
NUMBER OF BLADES	3 (OPTIONAL 5)		
POWER REQUIREMENTS	40 HP (30 kW)		
TRACTOR FIT (HOLDER)	C70 - C270	C70 - C270 - C992 - S75 - S100 - S130	

SNOW BLOWERS

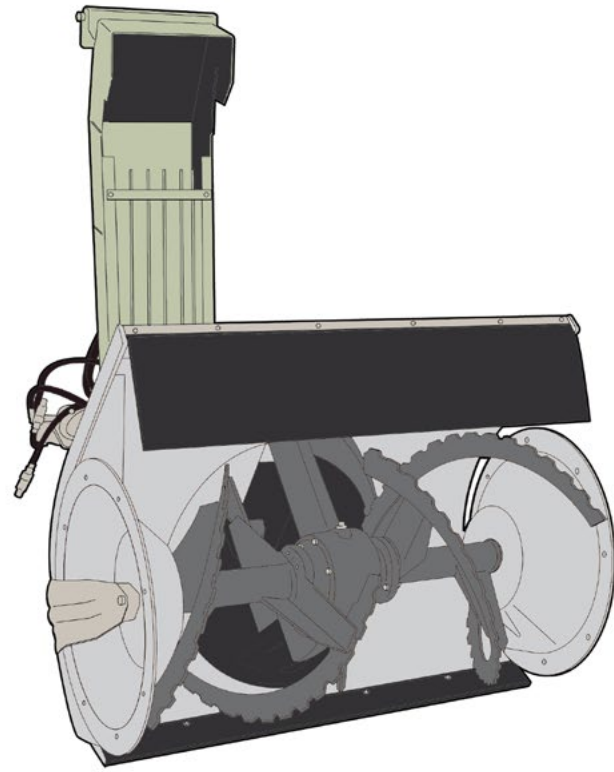

PTO DRIVEN RIBBON STYLE SNOW BLOWER

MADE IN EU

STANDARD FEATURES	HQWRS CUTTING EDGES & SKID SHOES - WEAR RESISTANT EXCHANGEABLE PLATE INSERT IN THE IMPELLER HOUSING - FLAT FACE COUPLINGS
AVAILABLE OPTIONS	HYDRAULIC TOP LINK - 39" (1000 mm) CHUTE EXTENSION (BCE-039-01) - TRUCK LOADING CHUTE w/ DOUBLE FLAP (TLC-039-01) - <i>ADDITIONAL SIZES AVAILABLE</i>
TRACTOR REQUIREMENTS	CAT I CAT II (3-POINT HITCH) - 2 SETS OF HYDRAULIC QUICK COUPLERS (DOUBLE ACTING) - 1 3/8" - 6 SPLINE PTO SHAFT 540 RPM - COUNTERWEIGHT

MODEL	BCD-051-03	BCD-059-02
TOTAL WIDTH	51" (1300 mm)	59" (1500 mm)
CLEARING WIDTH	51" (1300 mm)	59" (1500 mm)
TOTAL HEIGHT	82.6" (2100 mm)	
HOUSING HEIGHT	35.4" (900 mm)	
WEIGHT	992 lb (450 kg)	1091 lb (495 kg)
CHUTE	HYDRAULIC w/ 2 HYDRAULIC FLAPS	
CHUTE ROTATION	210°	
DRIVE ASSEMBLY	DIRECT DRIVE VIA GEAR BOX	
OVERLOAD PROTECTION	A CAM-TYPE CUT-OUT CLUTCH BETWEEN AXLE GEAR & BLOWER WHEEL PTO SHEAR PIN	
AUGER DIAMETER	25.6" (650 mm)	29.5" (750 mm)
IMPELLER DIAMETER	23.6" (600 mm)	
NUMBER OF BLADES	5	
POWER REQUIREMENTS	45 HP - 130 HP (33 kW - 95 kW)	
TRACTOR FIT (HOLDER)	C70 - C270	C992 - S75 - S100 - S130

DUMP BODIES

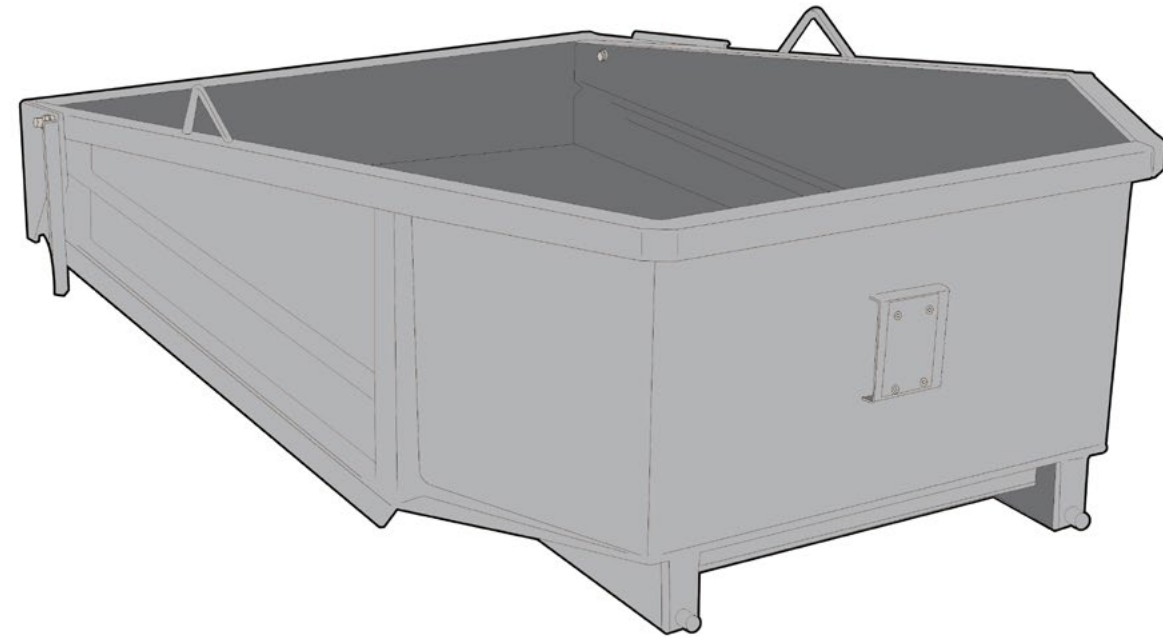

OVER ENGINE DUMP BODY

MADE IN CANADA

STANDARD FEATURES	11 GAUGE STEEL - TAPERED SIDE WALLS - REMOVABLE TAILGATE - POWDER COAT - HQWRS HOUSING MATERIAL
AVAILABLE OPTIONS	STAINLESS STEEL
TRACTOR REQUIREMENTS	OVER-ENGINE PLATFORM

MODEL	DBO-033-01	DBO-100-02	DBO-100-100	DBO-100-75
WIDTH	38" (965 mm)	42" (1066 mm)	50" (1270 mm)	45" (1143 mm)
LENGTH	46.5" (1181 mm)	63" (1600 mm)	68" (1727 mm)	68" (1727 mm)
HEIGHT TAPERED FRONT - REAR	22.5" (571 mm)	20" (508 mm)	22" (558 mm)	23" (584 mm)
WEIGHT	230 lb (104 kg)	295 lb (133 kg)	315 lb (143 kg)	305 lb (138 kg)
CAPACITY	0.33 cu yard (252 L)	1 cu yard (765 L)	1.1 cu yard (841 L)	1 cu yard (765 L)
TRACTOR FIT (HOLDER)	C70 - C270	C992	S100 - S130	S75

DROP SPREADERS

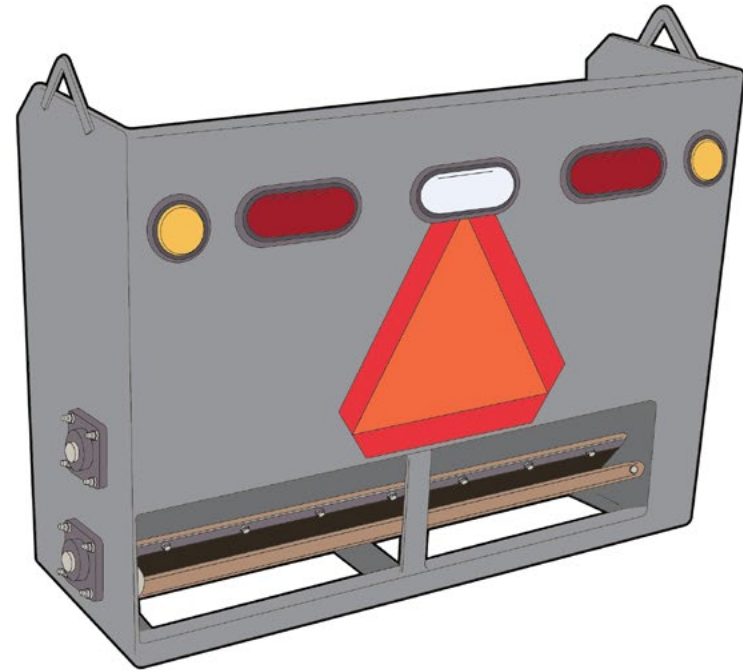

REAR MOUNT DROP SPREADER - HYDRAULICALLY DRIVEN

MADE IN CANADA

STANDARD FEATURES	FLAT FACE COUPLINGS - HQWRS HOUSING MATERIAL - STAINLESS STEEL CAMS ON THE ROLL SHAFT - LED: BRAKE LIGHTS, REVERSE LIGHTS & SIGNAL LIGHTS - ADJUSTABLE MATERIAL FLOW RATE
AVAILABLE OPTIONS	STAINLESS STEEL - SPILL PROTECTOR/ENHANCER - TARP/COVER - SUPPORT STAND (SET OF 3) DSS-000-01
TRACTOR REQUIREMENTS	REAR BUMPER - FLOW DIVIDER 1

MODEL	SAD-033-01	SAD-050-01	SAD-062-01	SAD-050-75
CAPACITY	0.33 cu yard (255 L)	0.5 cu yard (382 L)	0.62 cu yard (478 L)	0.33 cu yard (255 L)
WIDTH	40" (1016 mm)	44" (1117 mm)	52" (1320 mm)	44" (1117 mm)
LENGTH	15" (381 mm)			
HEIGHT	30.5" (774 mm)	36" (914 mm)		37" (939 mm)
WEIGHT	350 lb (159 kg)	430 lb (195 kg)	485 lb (220 kg)	380 lb (172 kg)
DEPTH	16" (406 mm)	22" (558 mm)		16" (406 mm)
SPREADING WIDTH	36" (914 mm)	40" (1016 mm)	48" (1219 mm)	40" (1016 mm)
MATERIAL TYPE	SALT - SAND - MIX			
POWER REQUIREMENTS	40 HP (30 kW)			
TRACTOR FIT (HOLDER)	C70 - C270	C992	S100 - S130	S75

BROADCAST SPREADER

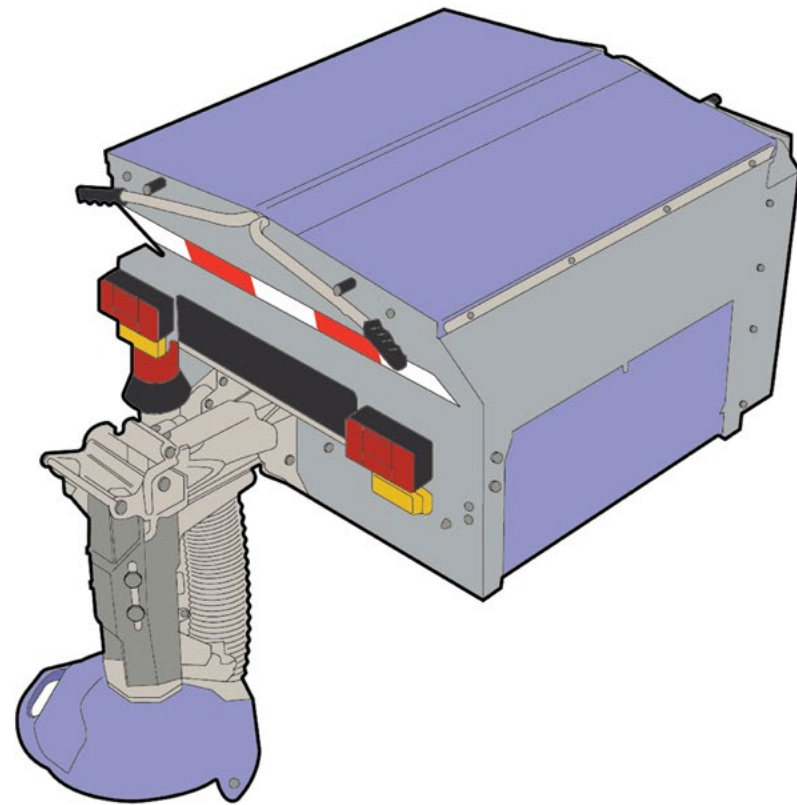

OVER ENGINE BROADCAST SPREADER - HYDRAULICALLY DRIVEN

MADE IN EU

STANDARD FEATURES	DRY SPREADING SYSTEM - FLAT-FACE COUPLINGS - WORK LIGHT - SUB-FRAME FOR HOLDER C250-C270 - STAINLESS STEEL SPINNER DISC & AGITATOR - MESH SCREEN - FOLDABLE TARPAULIN COVER - REAR SPLASH GUARD - SUPPORT LEGS w/ CASTOR WHEELS
AVAILABLE OPTIONS	PRE-WET MODULE - ADDITIONAL BEACON LIGHT - REAR CAMERA
MULTIMATIC DIGITAL CONTROL BOX	DOSAGE - SPRAYING WIDTH - HOURS COUNTER - DAILY LOGS - MATERIAL & DISTANCE COUNTER - SERVICE FUNCTIONS
TRACTOR REQUIREMENTS	OVER-ENGINE PLATFORM - HIGH-FLOW PUMP (MINIMUM 13 gpm (50 L /min) IS REQUIRED)

MODEL	SAB-085-01
HOPPER VOLUME	0.85 cu yard (0.65 m ³)
DELIVERY METHOD	AUGER w/ AGITATOR
SPREADING METHOD	ADJUSTABLE SPINNER DISC
SPREADING WIDTH	3' - 19' (1 m - 8 m)
SPREADING DOSAGE	5-250 g / m ² w/ 5g / m ² step
SPINNER DISC	STAINLESS STEEL ø 25" (647 mm)
MOUNTED HEIGHT	+/- 76" (1930 mm) (DEPENDING ON TIRES)
WEIGHT (EMPTY)	992 lb (450 kg)
MATERIAL TYPE	SALT - SAND - GRIT
POWER REQUIREMENTS	45 HP - 74 HP (33 kW - 55 kW)
TRACTOR FIT (HOLDER)	C70 - C270

BRINE SPRAYER

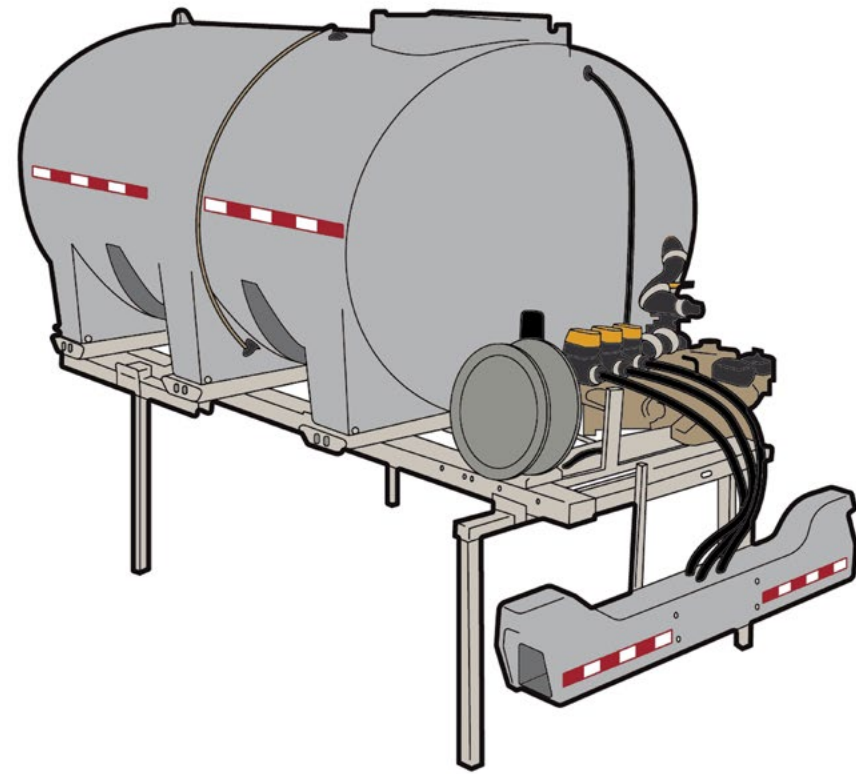

MADE IN CANADA

BRINE SPRAYER

STANDARD FEATURES	DOUBLE SPRAY BAR SYSTEM - BAFFLE BALL SURGE CONTROL - FAST FILL SYSTEM - TRI-ZONE SPRAY SELECTION - AUTO DRAIN SUMP BASE - BUILT-IN FORK SLOTS - RUST ARMOUR STAINLESS FRAME
AVAILABLE OPTIONS	STORAGE STANDS - LIGHTS - SECURING BAR - PUMP OPTIONS: HIGH FLOW 12-VOLT, GAS or HYDRAULIC
TRACTOR REQUIREMENTS	OVER-ENGINE PLATFORM

MODEL	BSP-250-75
TOTAL VOLUME	250 gal (946 L)
LENGTH	81" (2057 mm)
WIDTH	48" (1219 mm)
HEIGHT	39" (991 mm)
WEIGHT (EMPTY)	475 lb (215 kg)
FRAME TYPE	STAINLESS STEEL
HOSE LENGTH	100' (30 m)
MOUNTING	4 TIE-DOWN SLOTS
TANK TYPE	SINGLE-PIECE ROTO MOLD HDPE
SPRAY GUN TYPE	ADJUSTABLE JET/FAN
POWER REQUIREMENTS	70 HP - 130 HP (52 kW - 97 kW)
TRACTOR FIT (HOLDER)	S75 - S100 - S130

SWEEPERS

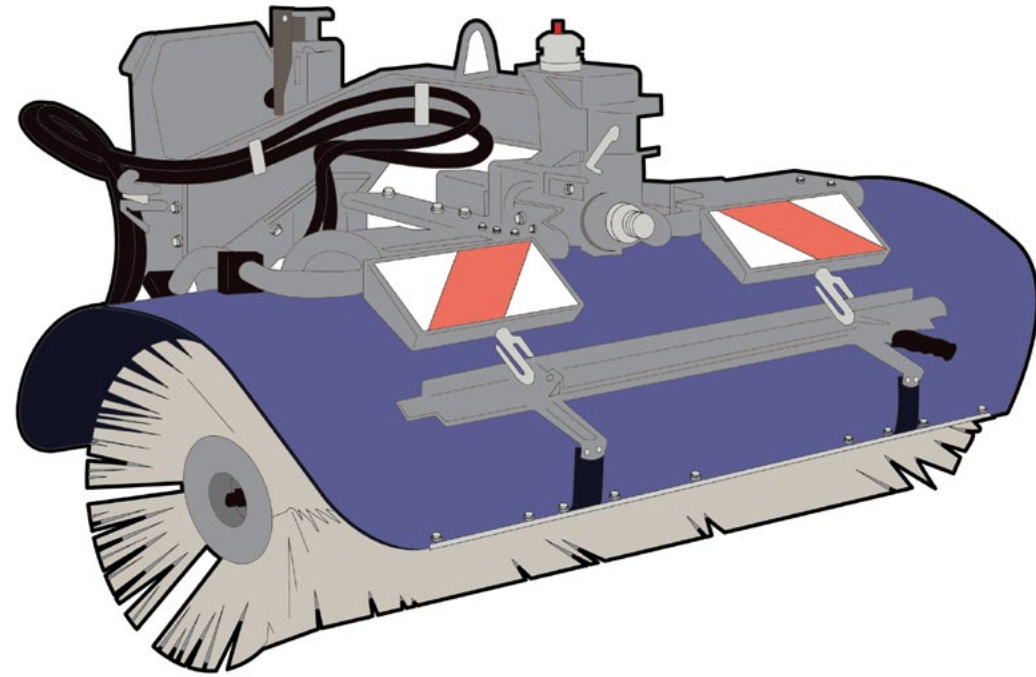

HYDRAULIC SWEEPER - CENTRE DRIVEN

MADE IN EU

STANDARD FEATURES	FLAT-FACE COUPLINGS - HOLDER C250-C270 ADAPTOR PLATE - ADJUSTABLE BROOM COVER - ONLY FOR SCD-059-01: CASTOR WHEEL
AVAILABLE OPTIONS	ONLY FOR SCD-059-01: WET-KIT (SPRAY NOZZLES - ELECTRICAL PUMP) (REGULAR WATER TANK IS REQUIRED)
TRACTOR REQUIREMENTS	CAT I (3-POINT HITCH) - 1 SET OF HYDRAULIC QUICK COUPLERS (DOUBLE ACTING) ONLY FOR SCD-059-01: CAT II (IN ADDITION)

MODEL	SCD-055-01	SCD-059-01
TOTAL WIDTH	57" (1447 mm)	61" (1550 mm)
CLEARING WIDTH STRAIGHT	55" (1400 mm)	59" (1500 mm)
CLEARING WIDTH ANGLED	59" (1500 mm) at 26°	63" (1600 mm) at 32°
TURNING ANGLE (L/R)	26°	32°
OSCILLATION	NO	18°
TRANSPORT HEIGHT	29" (735 mm)	41" (1050 mm)
BRUSH DIAMETER	21.6" (550 mm)	23.6" (600 mm)
BRUSH MATERIAL	POLYPROPYLENE	
WEIGHT	260 lb (118 kg)	529 lb (240 kg)
TORQUE TO THE SHAFT	147 lb*f (200 Nm)	479 lb*f (650 Nm)
POWER REQUIREMENTS	FLOW DIVIDER 1 OR HIGH FLOW PUMP 6.6 gpm (25 L /min)	HIGH FLOW PUMP 10 gpm (40 L /min)
TRACTOR FIT (HOLDER)	C70 - C270 - C992 - S75	C70 - C270 - C992 - S75 - S100 - S130

SWEEPERS

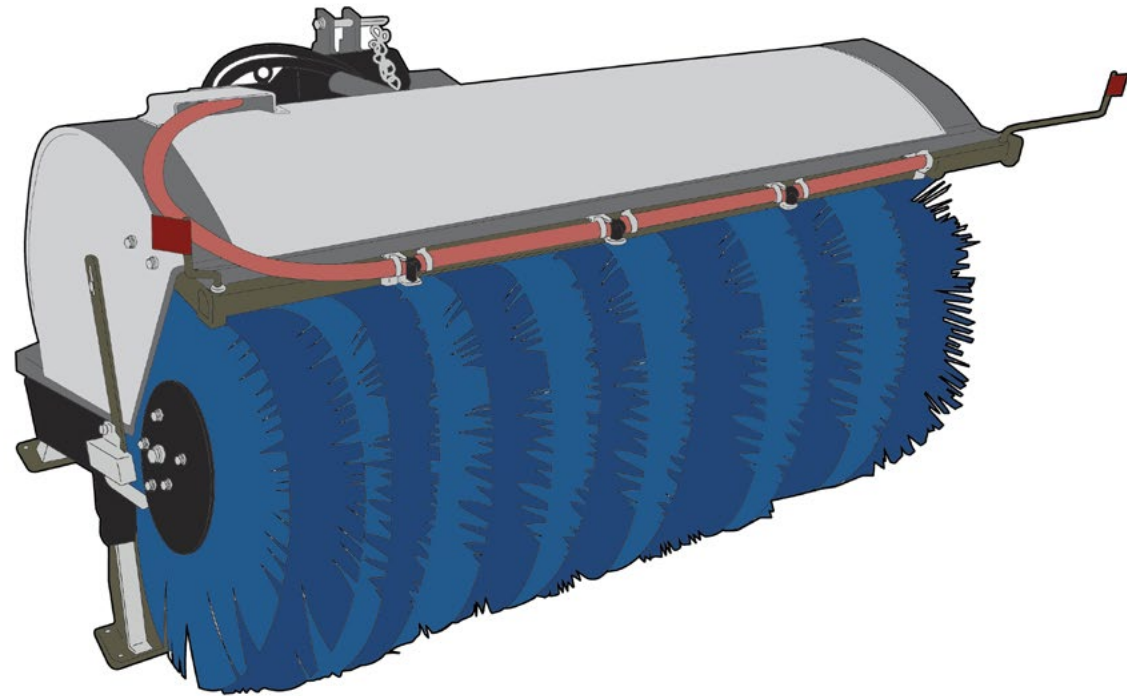

PTO DRIVEN SWEEPER WITHOUT WET KIT

MADE IN CANADA

STANDARD FEATURES	PU COWLING - PARKING LEGS - POLY STEEL COMBINATION BRUSHES - WATER SPRAY BAR - WATER PUMP - ADAPTER PLATE FOR WHEEL KIT
AVAILABLE OPTIONS	STAINLESS STEEL OR STEEL COWLING - WHEEL KIT HYDRAULIC DRIVEN MODELS AVAILABLE
TRACTOR REQUIREMENTS	CAT I CAT II (3-POINT HITCH)

MODEL	SPT-048-02	SPT-060-02	SPT-072-02
TOTAL WIDTH	53" (1346 mm)	65" (1651 mm)	77" (1955 mm)
CLEARING WIDTH STRAIGHT	48" (1219 mm)	60" (1524 mm)	72" (1828 mm)
CLEARING WIDTH ANGLED 30°	42" (1066 mm)	52" (1320 mm)	62" (1574 mm)
HEIGHT	38" (965 mm)		
BRUSH DIAMETER	32" (812 mm)		
SWING ANGLE	30°		
DRIVE ASSEMBLY	SIDE DRIVE VIA GEARBOX & CHAIN		
TYPE	MECHANICAL		
WEIGHT	685 lb (310 kg)	780 lb (353 kg)	860 lb (390 kg)
POWER REQUIREMENTS	40 HP (30 kW)		
TRACTOR FIT (HOLDER)	C70 - C270	C70 - C270 - C992 - S75 - S100 - S130	C992 - S75 - S100 - S130

SWEEPERS

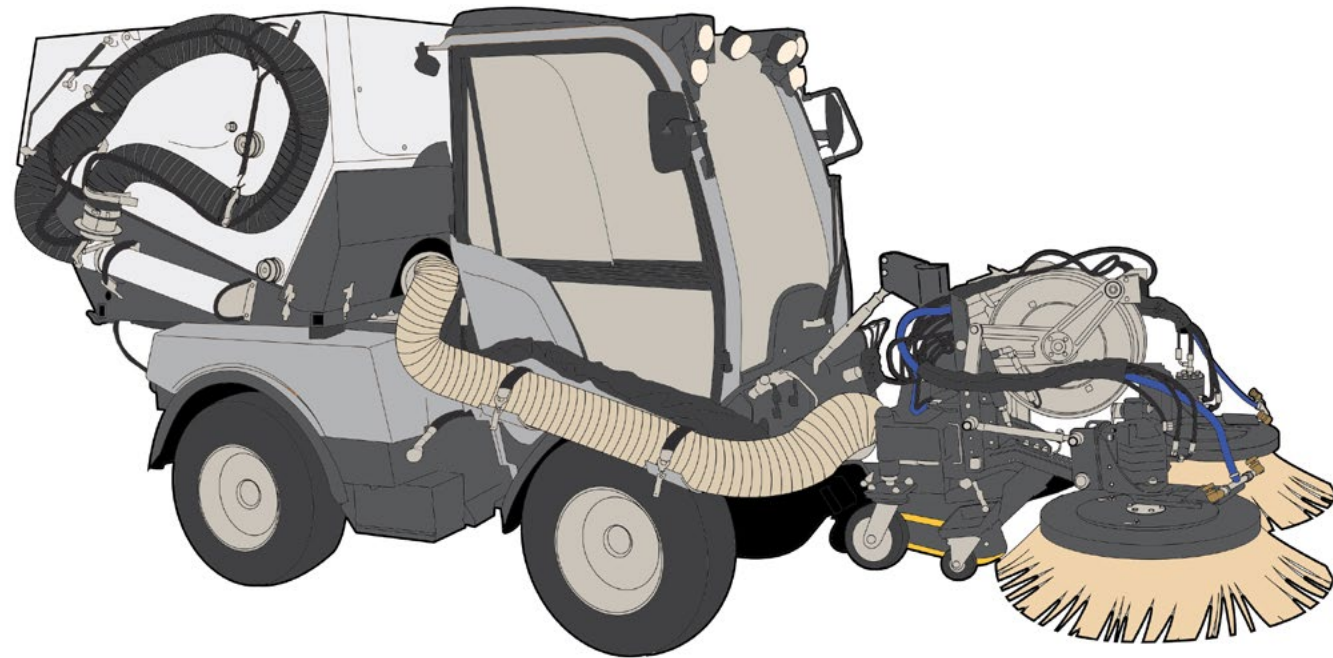

VACUUM SWEEPER

MADE IN EU

STANDARD FEATURES

ROBUST ALUMINUM CONTAINER - REDUCED NOISE OUTPUT -
REDUCED FUEL CONSUMPTION - REAR VIEW CAMERA -
HAND-HELD SUCTION HOSE

AVAILABLE OPTIONS

RIGHT OR LEFT HAND BRUSH OPTIONS ARE AVAILABLE AS A
WEED BRUSH w/ HYDRAULIC INCLINATION ADJUSTMENT

MODEL	SVC-072-02	SVC-200-01
HOPPER (GROSS)	1.57 cu yard (1.2 m ³)	2.1 cu yard (1.6 m ³)
HOPPER (NET)	1.05 cu yard (0.8 m ³)	1.56 cu yard (1.19 m ³)
FRESH WATER TANK	58 gal (219 L)	74 gal (280 L)
RECYCLED WATER	approx. 40 gal (151 L)	up to 137 gal (518 L)
TOTAL HEIGHT	from 84" (2133 mm)	approx. 90" (2286 mm)
TOTAL OUTER WIDTH	from 44" (1117 mm)	approx. 63" (1600 mm)
PLATE BRUSH DIAMETER	33" (838 mm)	
SWEEPING WIDTH SUCTION MOUTH	78" (1981 mm)	
POWER REQUIREMENTS	45 HP - 74 HP (33 kW - 55 kW)	70 HP - 130 HP (52 kW - 97 kW)
TRACTOR FIT (HOLDER)	C70 - C270	S75 - S100 - S130

STEAM CLEANER

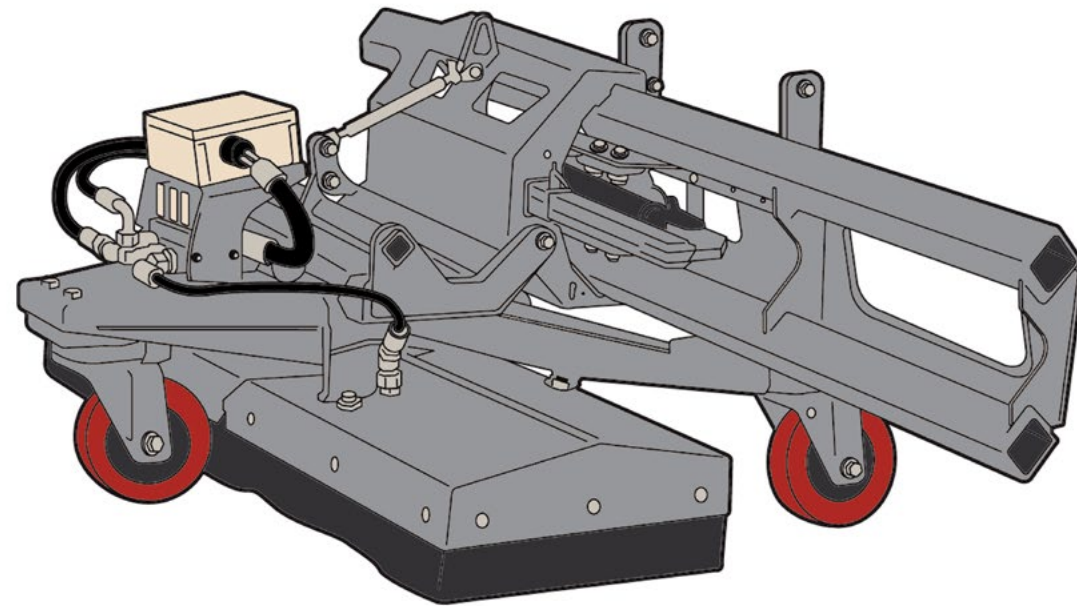

HOT WATER WEED KILLER

MADE IN EU

STANDARD FEATURES	SPECIAL HOT WATER NOZZLES FOR HOMOGENEOUS APPLICATION - STORAGE VIA A MAINTENANCE-FREE SPRING ELEMENT - AN IMPELLER FOR OPTIMAL GROUND-SURFACE ADAPTATION - TILT ADJUSTMENT - STORAGE CART w/ WHEELS FOR EASY MOUNTING
AVAILABLE OPTIONS	LATERAL NOZZLES (MOUNTING ON BOTH SIDES POSSIBLE)
TRACTOR REQUIREMENTS	OIL DEMAND 1.3 gpm (5 L /min)

MODEL	HWK-317-01
LENGTH	30" (770 mm)
TOTAL WIDTH	47" (1200 mm)
WORKING WIDTH	39" (1000 mm)
HEIGHT	23" (540 mm)
WEIGHT	132 lb (60 kg)
UNIT MATERIAL	STAINLESS STEEL V2A
POWER REQUIREMENTS	45 HP - 130 HP (33 kW - 97 kW)
TRACTOR FIT (HOLDER)	C70 - C270 - C992 - S75 - S100 - S130

MOWERS

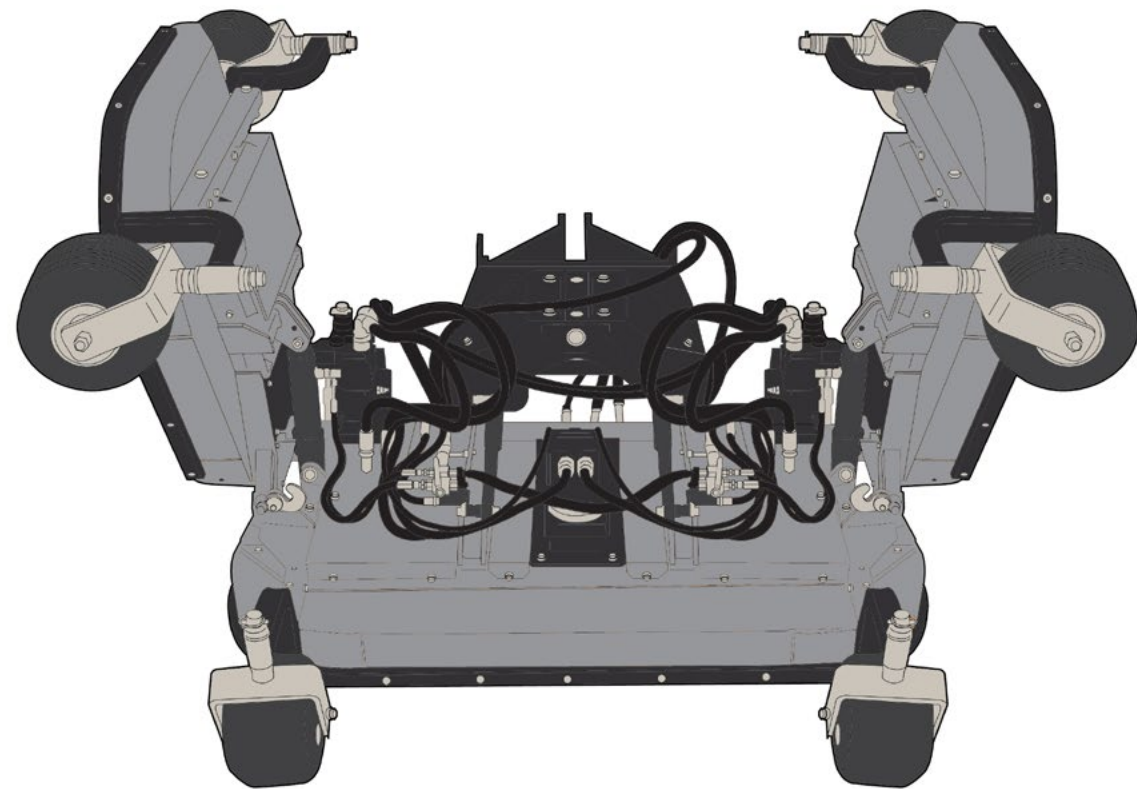

HYDRAULICALLY DRIVEN TRI-DECK ROTARY MOWER

MADE IN EU

STANDARD FEATURES	MECHANICAL TILT UP - AUTOMATIC SHUT-OFF OF THE SIDE WINGS WHEN RAISED MORE THAN 15" (400 mm) - CUT 10° BELOW LEVEL AND 15° ABOVE (WHEN FLOATED) - HYDRAULIC TRANSMISSION VIA DIRECT DRIVE
AVAILABLE OPTIONS	HYDRAULIC TILT UP MECHANICAL MAIN DECK
TRACTOR REQUIREMENTS	CAT I CAT II - 3 POINT HITCH - 2 SETS OF HYDRAULIC QUICK COUPLINGS (DOUBLE ACTING) w/ FLOAT MODE - HIGH-FLOW PUMP - COUNTERWEIGHT - TURF TIRES

MODEL	MTD-098-02	MTD-114-02
LARGEST WIDTH	100" (2535 mm)	117" (2975 mm)
TRANSPORT WIDTH	69" (1750 mm)	79" (2000 mm)
LARGEST LENGTH	61" (1550 mm)	65" (1655 mm)
LARGEST HEIGHT	20" (500 mm)	
TRANSPORT HEIGHT	32" (820 mm)	36" (920 mm)
CUTTING WIDTH	98" (2480 mm)	114" (2900 mm)
CUTTING HEIGHT	1" - 3" (30 mm - 80 mm)	
NECESSARY FLOW	16 gal @ 3625 psi (60 L /min @ 250 bar)	18 gal @ 3625 psi (70 L /min @ 250 bar)
NUMBER OF ROTORS	5	
NUMBER OF KNIVES	5 x 21" (533 mm)	5 x 24" (620 mm)
TIRES	AIR RUBBER TIRES (6) 10" x 3"	
WEIGHT	804 lb (365 kg)	970 lb (440 kg)
POWER REQUIREMENTS	34 HP (25 kW)	41 HP (30 kW)
TRACTOR FIT (HOLDER)	C70 - C270	C70 - C270 - C992 - S75 - S100 - S130

MOWERS

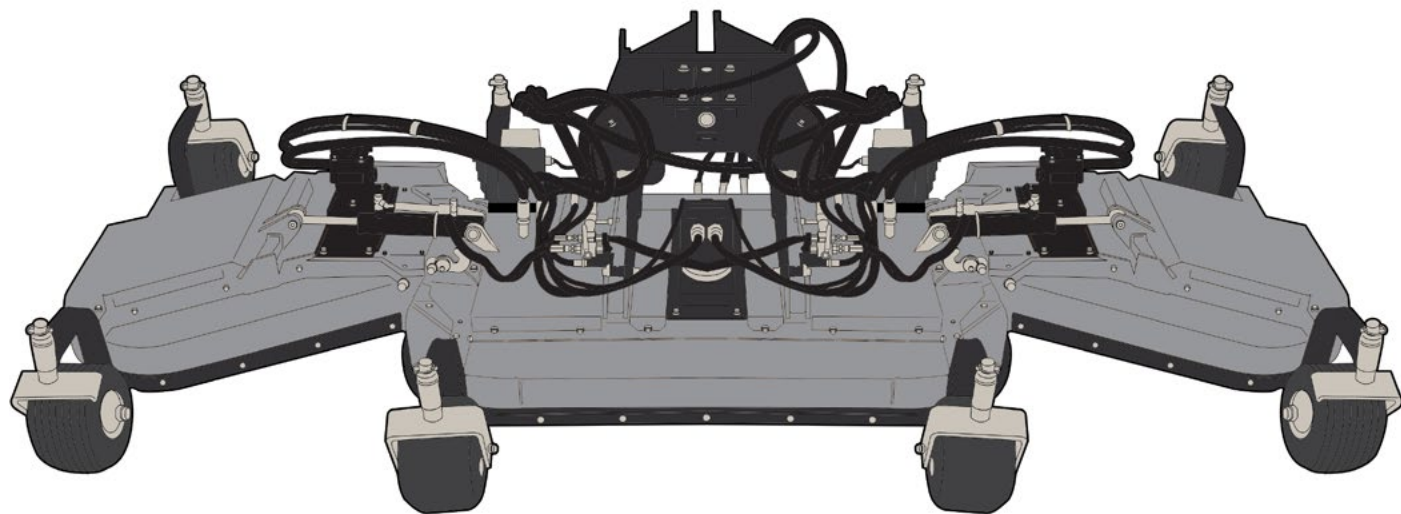

HYDRAULICALLY DRIVEN TRI-DECK ROTARY MOWER

MADE IN EU

STANDARD FEATURES	MECHANICAL TILT UP - AUTOMATIC SHUT-OFF OF THE SIDE WINGS WHEN RAISED MORE THAN 15" (400 mm) - CUT 10° BELOW LEVEL AND 15° ABOVE (WHEN FLOATED) - HYDRAULIC TRANSMISSION VIA DIRECT DRIVE
AVAILABLE OPTIONS	HYDRAULIC TILT UP MECHANICAL MAIN DECK
TRACTOR REQUIREMENTS	CAT I CAT II - 3 POINT HITCH - 2 SETS OF HYDRAULIC QUICK COUPLINGS (DOUBLE ACTING) w/ FLOAT MODE - HIGH-FLOW PUMP - COUNTERWEIGHT - TURF TIRES

MODEL	MTD-136-02	MTD-159-02
LARGEST WIDTH	139" (3525 mm)	162" (4120 mm)
TRANSPORT WIDTH	69" (1750 mm)	79" (2000 mm)
LARGEST LENGTH	64" (1625 mm)	68" (1735 mm)
LARGEST HEIGHT	24" (600 mm)	
TRANSPORT HEIGHT	47" (1200 mm)	57" (1450 mm)
CUTTING WIDTH	136" (3460 mm)	158" (4025 mm)
CUTTING HEIGHT	1" - 3" (30 mm - 80 mm)	
NECESSARY FLOW	16 gal @ 3625 psi (80 L /min @ 250 bar)	18 gal @ 3625 psi (85 L /min @ 300 bar)
NUMBER OF ROTORS	7	
NUMBER OF KNIVES	7	
TIRES	AIR RUBBER TIRES (8) 11" x 7" (279 mm x 177 mm)	
WEIGHT	1146 lb (520 kg)	1323 lb (600 kg)
POWER REQUIREMENTS	51 HP (37.5 kW)	56 HP (41.5 kW)
TRACTOR FIT (HOLDER)	C992 - S75 - S100 - S130	

MOWERS

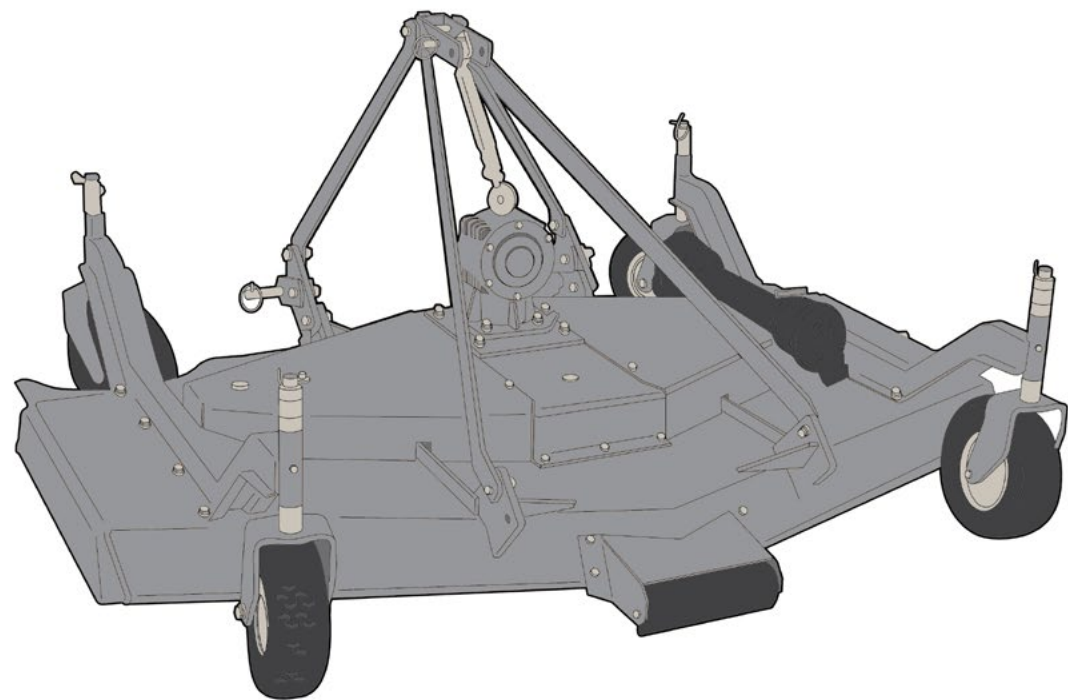

PTO DRIVEN ROTARY MOWER DECK

MADE IN USA

STANDARD FEATURES	GEARBOX w/ SPIRAL GEARS - MANUAL BELT TENSIONING - STAMPED STEEL REINFORCED WHEEL ARMS - DOUBLE BELT TRANSMISSION - CAST IRON PULLEYS - AXIAL GREASE FITTINGS - 8 GAUGE REINFORCED MOWER DECK - SAFETY CHAIN SHIELD
AVAILABLE OPTIONS	QUICK HITCH ADAPTER - MULCHING KIT - FRONT ANTI-SCALP ROLLER - REAR ROLLER - FRONT MOUNT (FACTORY INSTALLED)
AVAILABLE BLADE OPTIONS	STANDARD - LOW LIFT - HIGH LIFT - MULCHING
TRACTOR REQUIREMENTS	540 RPM - CAT I (3-POINT HITCH) - FRONT AND REAR TRACTOR MOUNTING

MODEL	MRT-060-01	MRT-072-01	MRT-084-01
WORKING WIDTH	60" (1524 mm)	72" (1829 mm)	84" (2134 mm)
OVERALL WIDTH	62" (1575 mm)	74" (1880 mm)	86" (2184 mm)
WEIGHT	534 lb (242 kg)	584 lb (265 kg)	674 lb (306 kg)
ROTOR RPM	3210	2605	2195
BLADE TIP SPEED	16,929 ft /min (5160 m /min)	16,732 ft /min (5100 m /min)	16,338 ft /min (4980 m /min)
NUMBER OF BLADES	3		
CUTTING HEIGHT	1" - 5" (25 mm - 127 mm)		
NUMBER OF BELTS & TYPE	2 SPBX		
DRIVELINE 1 3/8"	ASAE CAT 3		
TIRES	PNEUMATIC (4) 11" x 4" (279 mm x 101 mm)		
GEARBOX	SPIRAL GEARS w/ COOLING FINS		
POWER REQUIREMENTS	20 HP - 50 HP (15 kW - 37 kW)	25 HP - 50 HP (18 kW - 37 kW)	30 HP - 50 HP (22 kW - 37 kW)
TRACTOR FIT (HOLDER)	C70 - C270		

MOWERS

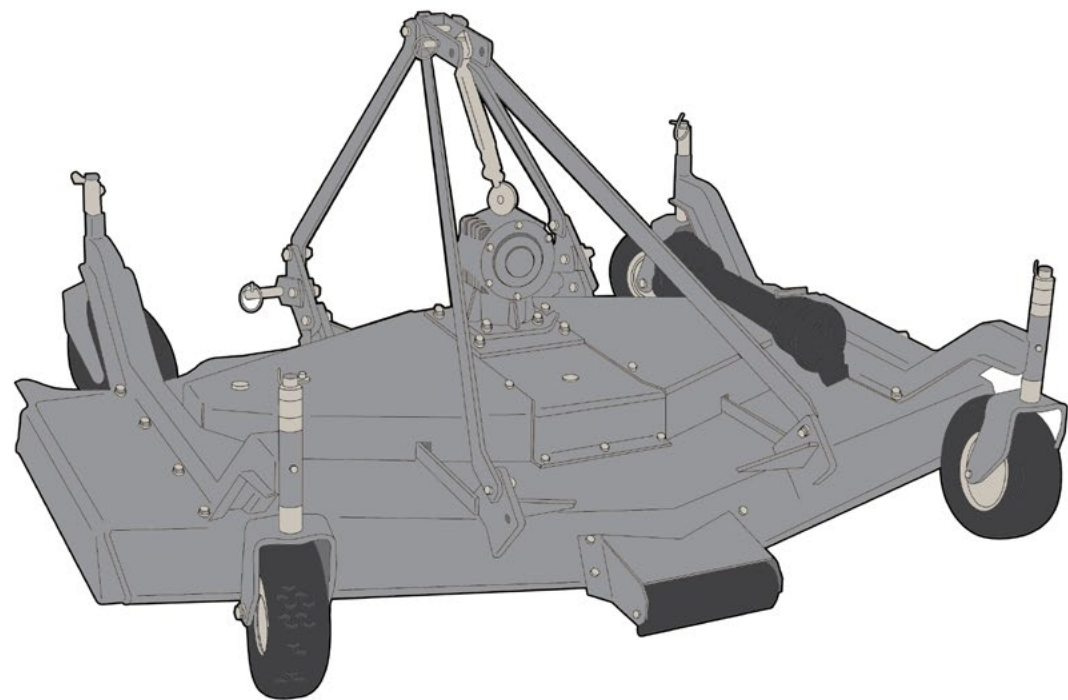

PTO DRIVEN ROTARY MOWER DECK

MADE IN USA

STANDARD FEATURES	FRONT ANTI-SCALP ROLLER - STAMPED STEEL REINFORCED WHEEL ARMS - MANUAL BELT TENSIONING - DOUBLE BELT TRANSMISSION - FREE SWINGING BLADES - CAST IRON PULLEYS - AXIAL GREASE FITTINGS - 8 GAUGE REINFORCED MOWER DECK - SAFETY CHAIN SHIELD
AVAILABLE OPTIONS	QUICK HITCH ADAPTER - FRONT MOUNT (FACTORY INSTALLED)
TRACTOR REQUIREMENTS	540 RPM - CAT I (3-POINT HITCH) - FRONT AND REAR TRACTOR MOUNTING

MODEL	MRT-090-01	MRT-110-01
WORKING WIDTH	90" (2286 mm)	110" (2794 mm)
OVERALL WIDTH	92" (2336 mm)	112" (2844 mm)
WEIGHT	1137 lb (515 kg)	1290 lb (585 kg)
ROTOR RPM	1750	1562
BLADE TIP SPEED	14,106 ft /min (4299 m /min)	14,998 ft /min (4571 m /min)
NUMBER OF BLADES	6	
CUTTING HEIGHT	1.3" - 5.3" (33 mm - 134 mm)	
NUMBER OF BELTS & TYPE	2 CX	
DRIVELINE 1 3/8"	ASAE CAT 4	
TIRES	PNEUMATIC (4) 13" x 6.5" (330 mm x 165 mm)	
GEARBOX	SPIRAL GEARS w/ COOLING FINS	
POWER REQUIREMENTS	30 HP - 70 HP (22 kW - 52 kW)	40 HP - 70 HP (29 kW - 52 kW)
TRACTOR FIT (HOLDER)	C992 - S75 - S100 - S130	

MOWERS

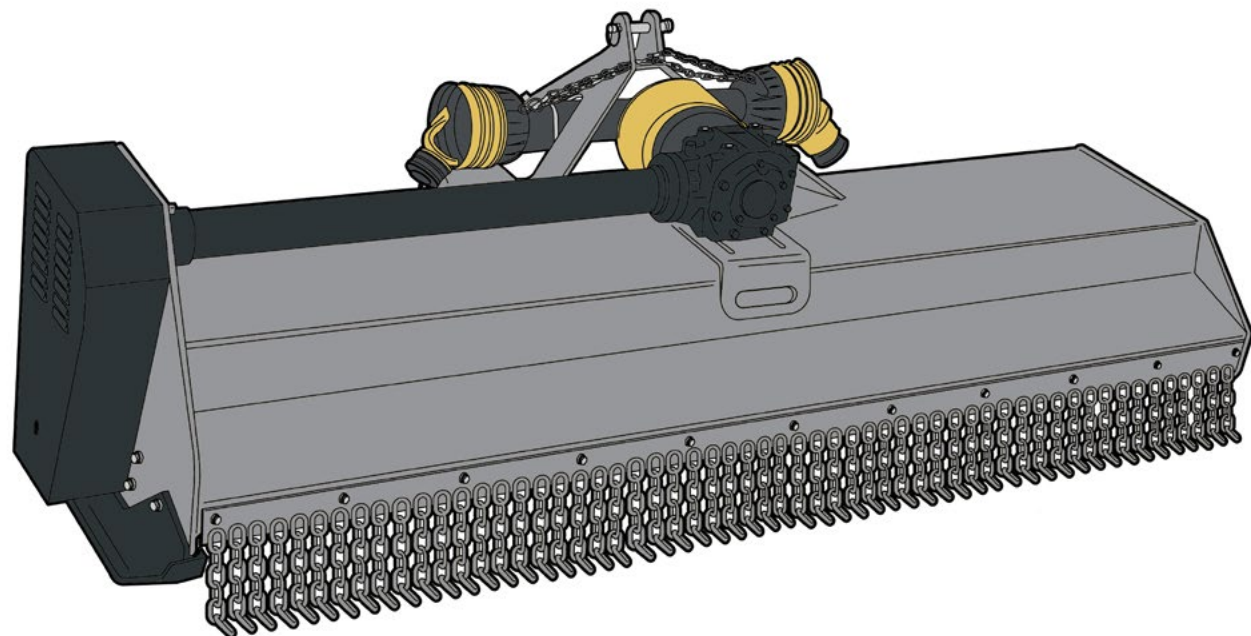

PTO DRIVEN FLAIL MOWER

MADE IN USA

STANDARD FEATURES	CAST IRON ROTOR SUPPORTS - BELT SHIELD FENDER - REPLACEABLE SIDE SKIDS - CLOCKWISE ROTOR ROTATION
AVAILABLE OPTIONS	GAUGE WHEELS - FRONT MOUNT - REVERSE ROTATION - METAL DUST SKIRT
AVAILABLE BLADE OPTIONS	DETHATCHING - REVERSE "Y" - TRIANGULAR PADDLE - HAMMER (ALL FACTORY INSTALLED)
TRACTOR REQUIREMENTS	540 RPM - CAT I CAT II (3-POINT HITCH) - FRONT AND REAR TRACTOR MOUNTING

MODEL	MFL-060-01	MFL-072-01	MFL-088-01
WORKING WIDTH	60" (1524 mm)	72" (1829 mm)	88" (2235 mm)
OVERALL WIDTH	71" (1803 mm)	85" (2159 mm)	99" (2515 mm)
WEIGHT	869 lb (394 kg)	955 lb (433 kg)	1078 lb (489 kg)
ROTOR RPM	2080		
BLADE TIP SPEED	8464 ft /min (2579 m /min)		
NUMBER OF BLADES	64	80	96
CUTTING HEIGHT	3/4" x 6" (19 mm - 152 mm)		
NUMBER OF BELTS & TYPE	2 CX		
DRIVELINE 1 3/8"	ASAE CAT 4 OVERRUNNING CLUTCH		
POWER REQUIREMENTS	30 HP - 70 HP (22 kW - 52 kW)	35 HP - 70 HP (26 kW - 52 kW)	40 HP - 70 HP (30 kW - 52 kW)
TRACTOR FIT (HOLDER)	C70 - C270	C70 - C270 - C992 - S75 - S100 - S130	S100 - S130

MOWERS

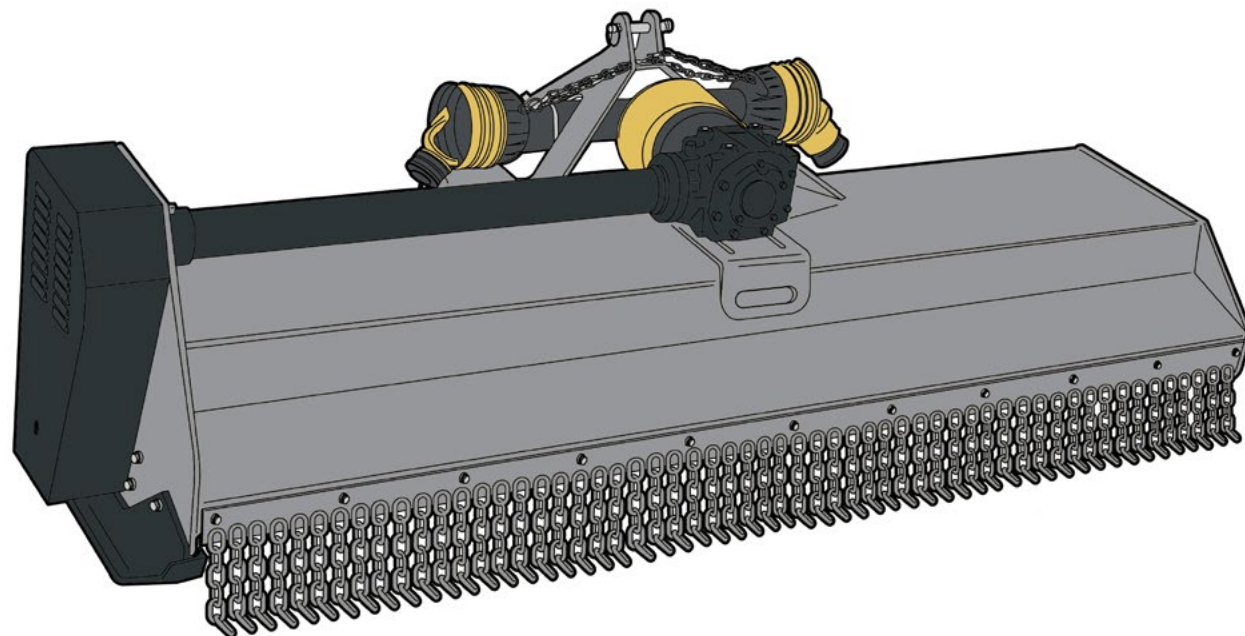

PTO DRIVEN FLAIL MOWER

MADE IN USA

STANDARD FEATURES	HEAVY DUTY BELT DRIVEN TRANSMISSION - HEIGHT ADJUSTMENT ROLLER - REVERSIBLE "A" FRAME - CLOCKWISE ROTOR ROTATION - CAST IRON ROTOR SUPPORTS - HYDRAULIC OFFSET CYLINDER
AVAILABLE OPTIONS	SIDE SKIDS - FRONT MOUNT (FACTORY INSTALLED) - GEARBOX W/ DUAL PTO (FACTORY INSTALLED)
TRACTOR REQUIREMENTS	540 RPM - CAT I CAT II (3-POINT HITCH) - FRONT AND REAR TRACTOR MOUNTING

MODEL	MFL-060-03	MFL-072-03
WORKING WIDTH	60" (1524 mm)	72" (1829 mm)
OVERALL WIDTH	69" (1752 mm)	81" (2057 mm)
WEIGHT	1257 lb (570 kg)	1345 lb (610 kg)
ROTOR RPM	1961	
BLADE TIP SPEED	8268 ft/ min (2520 m /min)	
NUMBER OF HAMMERS	16	20
CUTTING HEIGHT	3/4" x 5" (19 mm - 127 mm)	
NUMBER OF BELTS & TYPE	4 XPBX	
DRIVELINE 1 3/8"	ASAE CAT 6 OVERRUNNING CLUTCH	
HYDRAULIC SIDE-SHIFT	12" (304 mm)	16" (406 mm)
POWER REQUIREMENTS	40 HP - 80 HP (30 kW - 60 kW)	50 HP - 90 HP (37 kW - 67 kW)
TRACTOR FIT (HOLDER)	S75 - S100 - S130	C992 - S75 - S100 - S130

WATER TANKS

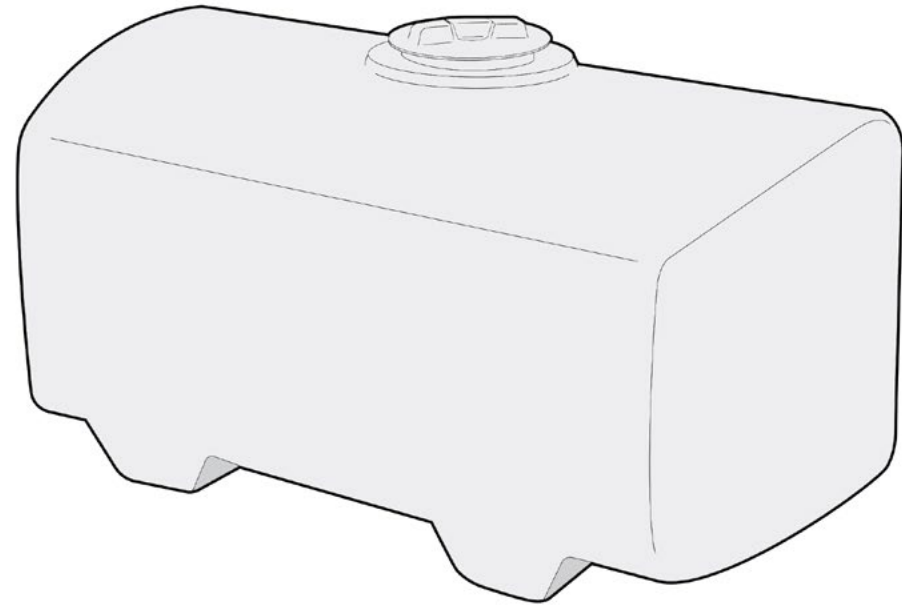

MADE IN CANADA

WATER TANK (WITHOUT BAFFLES)

STANDARD FEATURES	HOSE CONNECTIONS
MOUNTING OPTIONS	IN THE DUMP BODY (FRAME REQUIRED) ON THE PLATFORM (FRAME REQUIRED)
FRAME OPTIONS	WTF-100-01 (DUMP BODY MOUNT) WTF-100-02 (PLATFORM MOUNT)
TRACTOR REQUIREMENTS	OVER-ENGINE PLATFORM OR IN THE DUMP BODY

MODEL	WTA-100-01	WTA-150-01
TOTAL VOLUME	100 gal (440 L)	150 gal (568 L)
LENGTH	38" (965 mm)	48" (1219 mm)
WIDTH	30" (762 mm)	36" (914 mm)
HEIGHT	28" (711 mm)	
MATERIAL	POLYETHYLENE	
TRACTOR FIT (HOLDER)	C70 - C270	C992 - S75 - S100 - S130

WATER TANKS

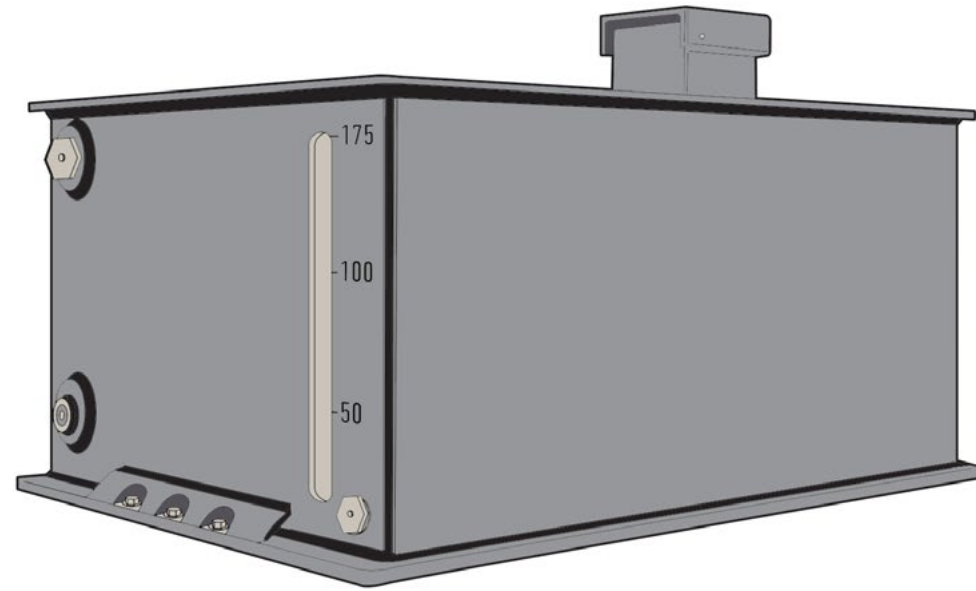

WATER TANK (WITH BAFFLES)

MADE IN CANADA

STANDARD FEATURES	HOSE CONNECTIONS - PLATFORM MOUNT
MOUNTING OPTIONS	ON THE PLATFORM ONLY
TRACTOR REQUIREMENTS	OVER-ENGINE PLATFORM

MODEL	WTA-175-01	WTA-250-01
TOTAL VOLUME	175 gal (771 L)	250 gal (946 L)
LENGTH	52" (1321 mm)	64" (1626 mm)
WIDTH	40" (1016 mm)	46" (1168 mm)
HEIGHT	25" (635 mm)	32.5" (825 mm)
MATERIAL	POLYETHYLENE	
TRACTOR FIT (HOLDER)	C70 - C270	C992 - S75 - S100 - S130

SPRAY BARS

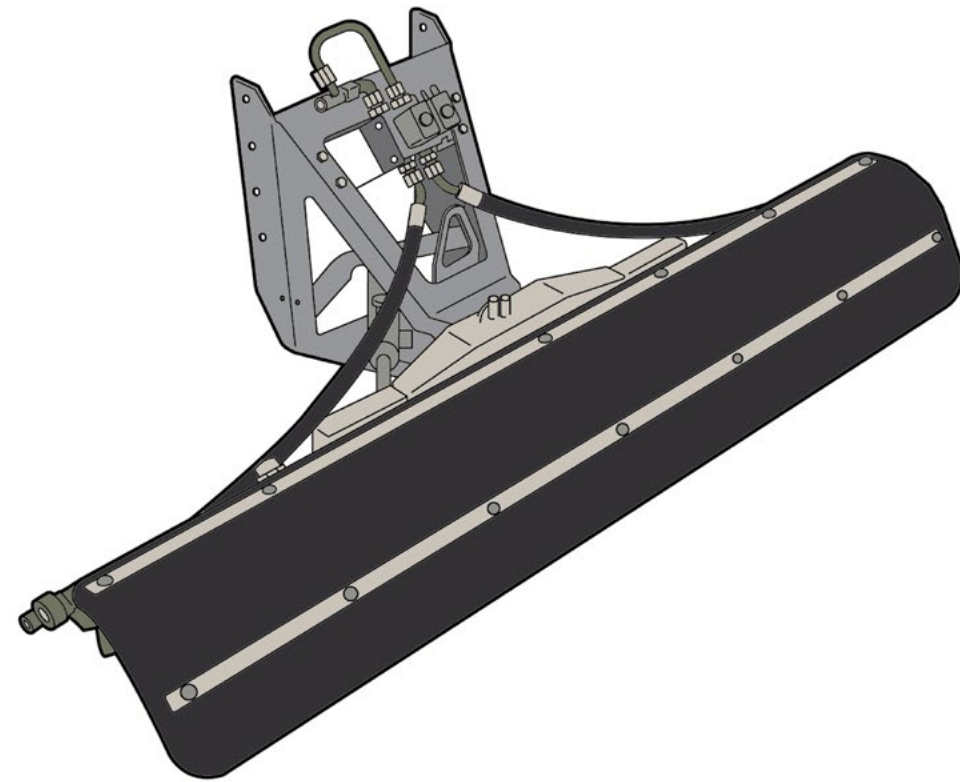

HYDRAULIC SWIVELING FRONT SPRAY BAR

MADE IN EU

STANDARD FEATURES	HYDRAULIC ANGLING (L/R) - MANUAL HEIGHT ADJUSTMENT - FRONT ADAPTER PLATE HOLDER C250-C270-C480-C992 - FLAT-FACE COUPLINGS - SUPPORT LEG
AVAILABLE OPTIONS	SPRAY GUARD - SIDE NOZZLES - 20" (500 mm) L/R TELESCOPIC EXTENSION
TRACTOR REQUIREMENTS	CAT I (3 POINT HITCH) - 1 SET OF HYDRAULIC QUICK COUPLINGS (DOUBLE ACTING)
OTHER REQUIREMENTS	WATER TANK SYSTEM WTS-171-02 OR WTS-171-03

MODEL	SPB-059-01	SPB-070-01
TOTAL WIDTH	59" (1500 mm)	70" (1778 mm)
WORKING WIDTH 30°	51" (1300 mm)	62" (1574 mm)
LENGTH	(19.6") 550 mm	
HEIGHT	(15.7") 400 mm	
WEIGHT	154 lb (70 kg)	165 lb (75 kg)
BAR MATERIAL	STAINLESS STEEL	
POWER REQUIREMENTS	3.9 gpm (15 L /min)	
WATER PRESSURE	725 psi @ 21 gal (50 bar @ 80 L) (w/ MEDIUM PRESSURE PUMP)	1883 psi @ 21 gal (130 bar @ 80 L) (w/ HIGH PRESSURE PUMP)
TRACTOR FIT (HOLDER)	C70 - C270	C70 - C270 - C992 - S75 - S100 - S130

WATERING ARM

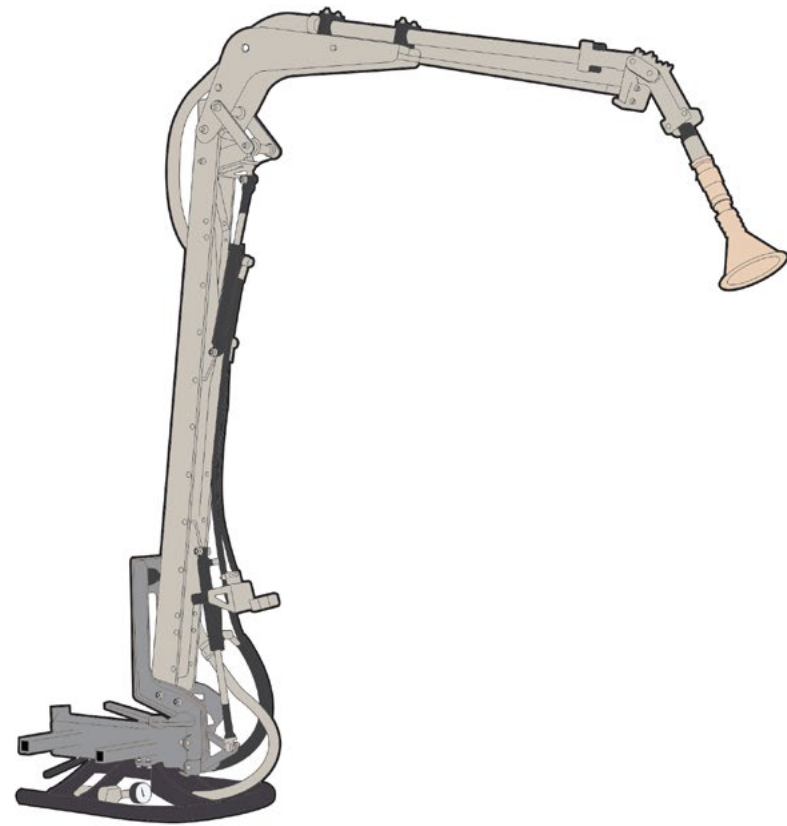

HYDRAULIC WATERING ARM

MADE IN EU

STANDARD FEATURES	ADAPTER PLATE HOLDER C250-C270-C480-C992 - FLAT SEALING COUPLINGS - ELECTRICAL ANGLING OF THE SPRAYING HEAD - STANDARD HOLDER JOYSTICK CONTROLS
AVAILABLE OPTIONS	FMC MULTIMATIC CONTROL BOX W/ JOYSTICK (WAR-161-02)
TRACTOR REQUIREMENTS	CAT I CAT II (3-POINT HITCH) - 2 SETS OF HYDRAULIC QUICK COUPLERS (DOUBLE ACTING)
OTHER REQUIREMENTS	WATER TANK SYSTEM WTS-171-01 OR WTS-171-02

MODEL	WAR-161-01
WORKING HEIGHT	161" (4100 mm)
SWIVEL RANGE (L/R)	250° (125° L/R) MAIN ARM: 55° TILT - SECONDARY ARM: 150° SWIVEL
SPRAYING HEAD ANGLING	170° ELECTRICALLY ADJUSTABLE
MATERIAL (BOTH ARMS)	STAINLESS STEEL
POWER REQUIREMENTS	13 gpm (51 L /min)
TRACTOR FIT (HOLDER)	C270 - C70 - C992 - S75 - S100 - S130

POWER ARMS

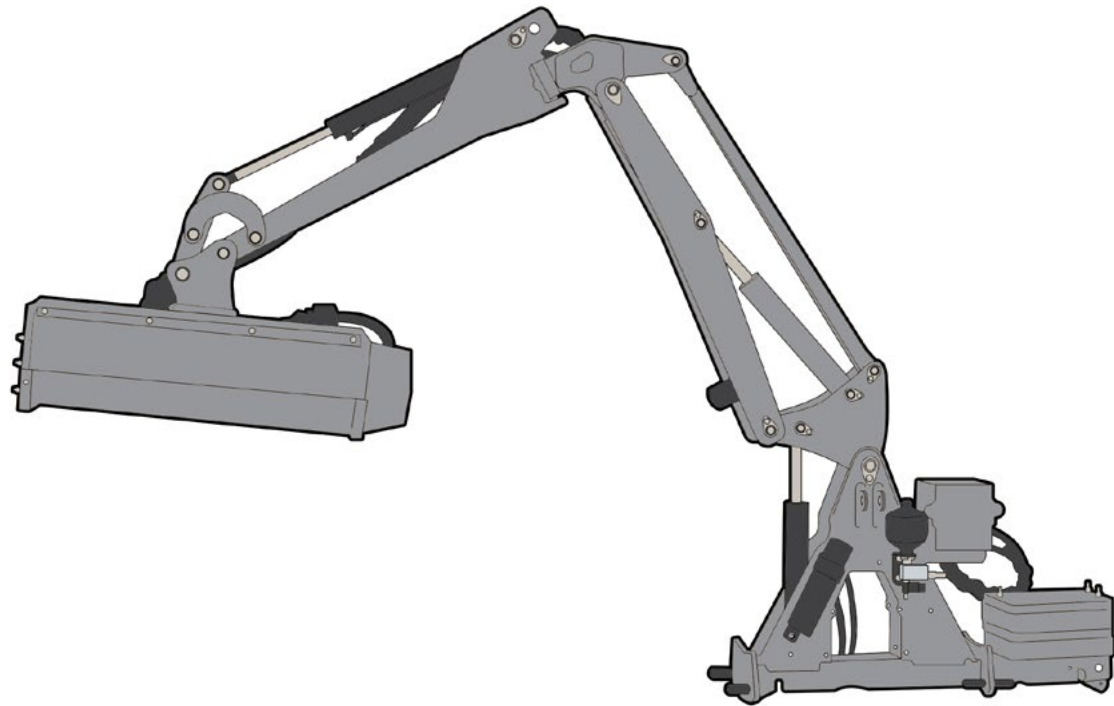

MULTI-PURPOSE HYDRAULIC POWER ARM (BOOM ARM)

MADE IN EU / UK

STANDARD FEATURES	HYDRAULIC WEIGHT TRANSFER - FLAT SEALING COUPLINGS - HYDRAULIC ANTI-CRASH PROTECTION - HOLDER MOUNTING GROUP - QUICK CHANGE SYSTEM FOR WORKING TOOLS
AVAILABLE OPTIONS	FMC MULTIMATIC CONTROL BOX w/ DIGITAL MOUSE
POWER ARM	DOES NOT INCLUDE HEAD
TRACTOR REQUIREMENTS	COUNTERWEIGHT

MODEL	PAR-157-01	PAR-157-02	PAR-157-03
REACH FROM TRACTOR CENTER	157" (3988 mm)		
OPERATION	HYDRAULIC - HI FLOW		1000 RPM - PTO DRIVEN
WEIGHT	approx. 639 lb (290 kg)		
POWER REQUIREMENTS	3.96 gpm @ 2900 psi (15 L /min @ 200 bar)		
TRACTOR FIT (HOLDER)	C992 - S75 - S100 - S130	C70 - C270	C992 - S75 - S100 - S130
MODEL	PAR-320-01		
REACH FROM TRACTOR CENTER	128" (3251 mm)		
OPERATION	HYDRAULIC		
WEIGHT	1058 lb (480 kg)		
POWER REQUIREMENTS	30 HP (22 kW)		
OIL TANK CAPACITY	16 gal (62 L)		
TRACTOR FIT (HOLDER)	C270 - C70 - C992 - S75 - S100 - S130		

SPECIAL APPLICATIONS

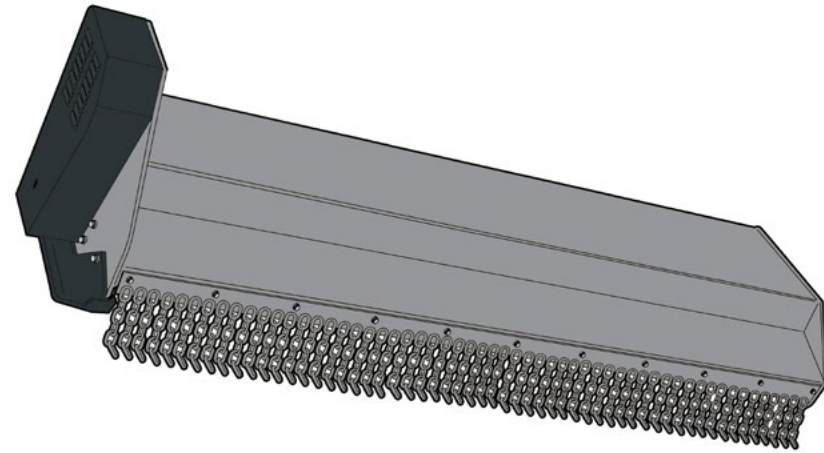

FLAIL HEAD

MADE IN EU

STANDARD FEATURES

QUICK CHANGE SYSTEM -
 DIRECT DRIVE VIA AXIAL PISTON ENGINE -
 SUPPORT ROLLER FOR CUTTING HEIGHT REGULATION -
 DOUBLE STONE GUARD AT THE FRONT
 (PLASTIC BAFFLE PLATES & CHAIN GUARD) -
 SIMPLE IMPACT PROTECTION AT THE BACK (RUBBER APRON)

TRACTOR REQUIREMENTS

MULTI-PURPOSE HYDRAULIC POWER ARM (BOOM ARM)
PAR-157-XX

MODEL	HMF-039-02
GRASS TRIM HEIGHT	CUT UP TO Ø 0.78" (20 mm)
WORKING WIDTH	31.5" (800 mm)
NUMBER OF BLADES	32 Y-BLADES
WEIGHT	approx. 363 lb (165 kg)

SPECIAL APPLICATIONS

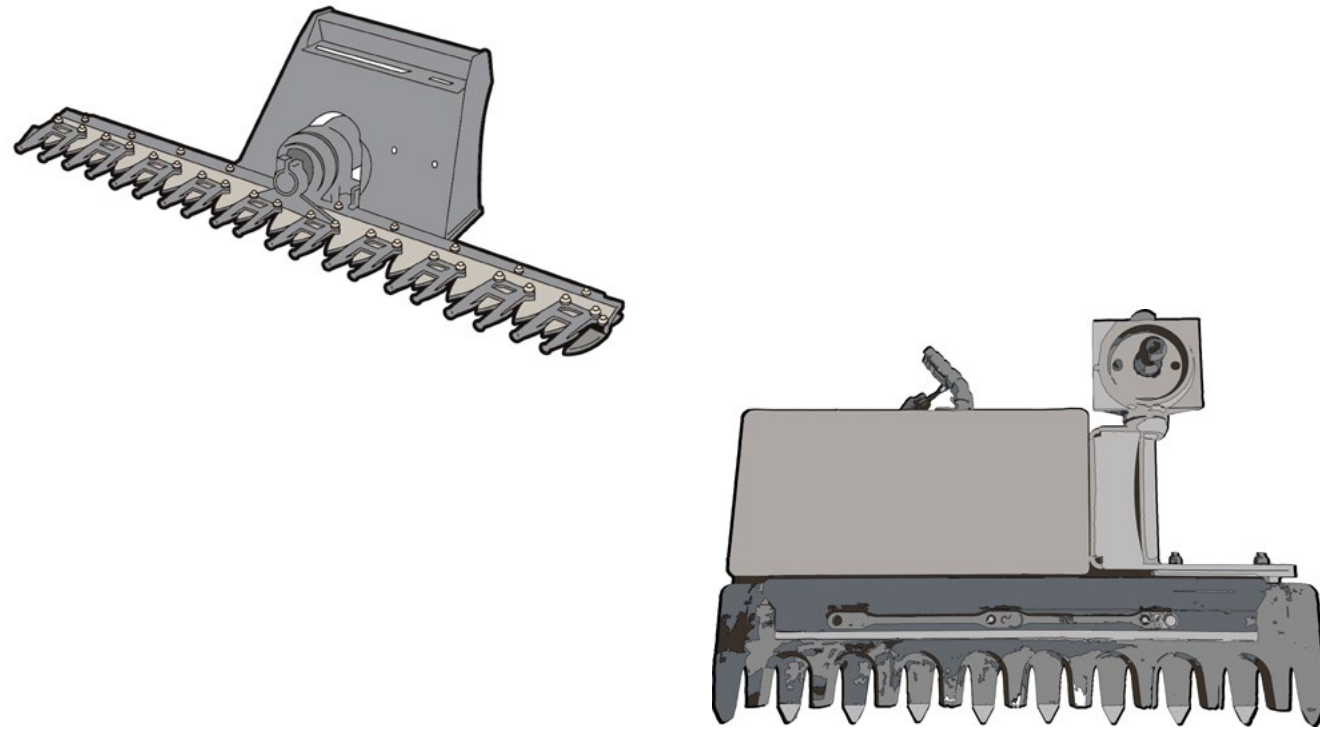

BRANCH CUTTERS

MADE IN UK / EU

STANDARD FEATURES	QUICK CHANGE SYSTEM
AVAILABLE OPTIONS	<i>ADDITIONAL SIZES AVAILABLE</i>
TRACTOR REQUIREMENTS	MULTI-PURPOSE HYDRAULIC POWER ARM (BOOM ARM) PAR-320-01 & PAR-157-XX

MODEL	BCH-059-01
CUTTING WIDTH	4'9" (1.5 m)
NUMBER OF BLADES	19
STROKES PER MINUTE	60
CUTTING CAPACITY	1.57" (40 mm)
MINIMUM FLOW	13.2 gpm (50 L /min)
PRESSURE	2611 psi (180 bar)
MODEL	BCH-053-01
CUTTING WIDTH	4.42' (1347 mm)
CUTTABLE BRANCH SIZE	max. 3.93' (1197 mm)
STROKES PER MINUTE	100
WEIGHT	410 lb (186 kg)

SPECIAL APPLICATIONS

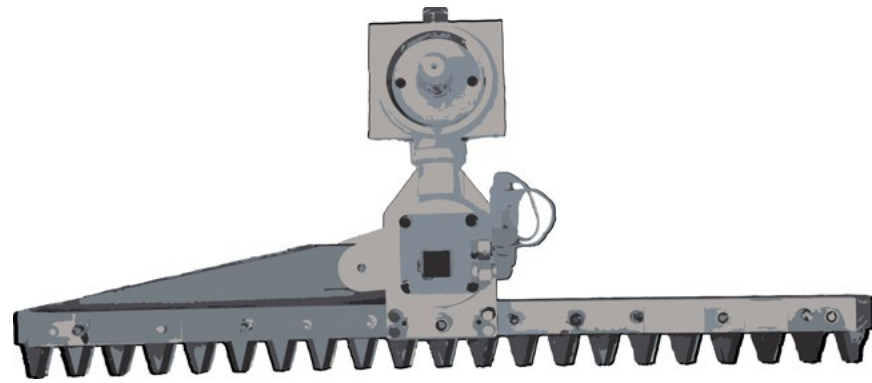
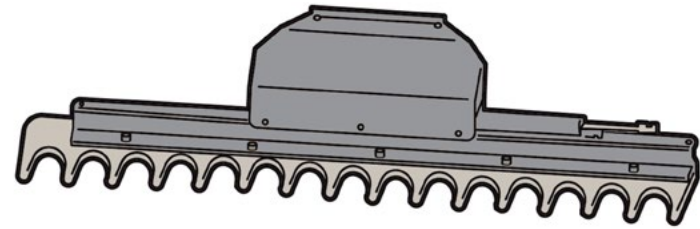

HEDGE TRIMMERS

MADE IN UK / EU

STANDARD FEATURES	QUICK CHANGE SYSTEM
AVAILABLE OPTIONS	<i>ADDITIONAL SIZES AVAILABLE</i>
TRACTOR REQUIREMENTS	MULTI-PURPOSE HYDRAULIC POWER ARM (BOOM ARM) PAR-320-01 & PAR-157-XX

MODEL	HCH-067-01
CUTTING WIDTH	5'6" (1.7 m)
NUMBER OF BLADES	26
STROKES PER MINUTE	60
CUTTING CAPACITY	3.94" (100 mm)
MINIMUM FLOW	13.2 gpm (50 L /min)
PRESSURE	3191 psi (220 bar)
MODEL	HCH-059-01
CUTTING WIDTH	4.9' (1493 mm)
CUTTABLE BRANCH SIZE	1.57" (40 mm)
STROKES PER MINUTE	36
WEIGHT	216 lb (98 kg)
SPEED CRANK MECHANISM	500 min-1
CAPACITY	14 HP (11 kW)

SPECIAL APPLICATIONS

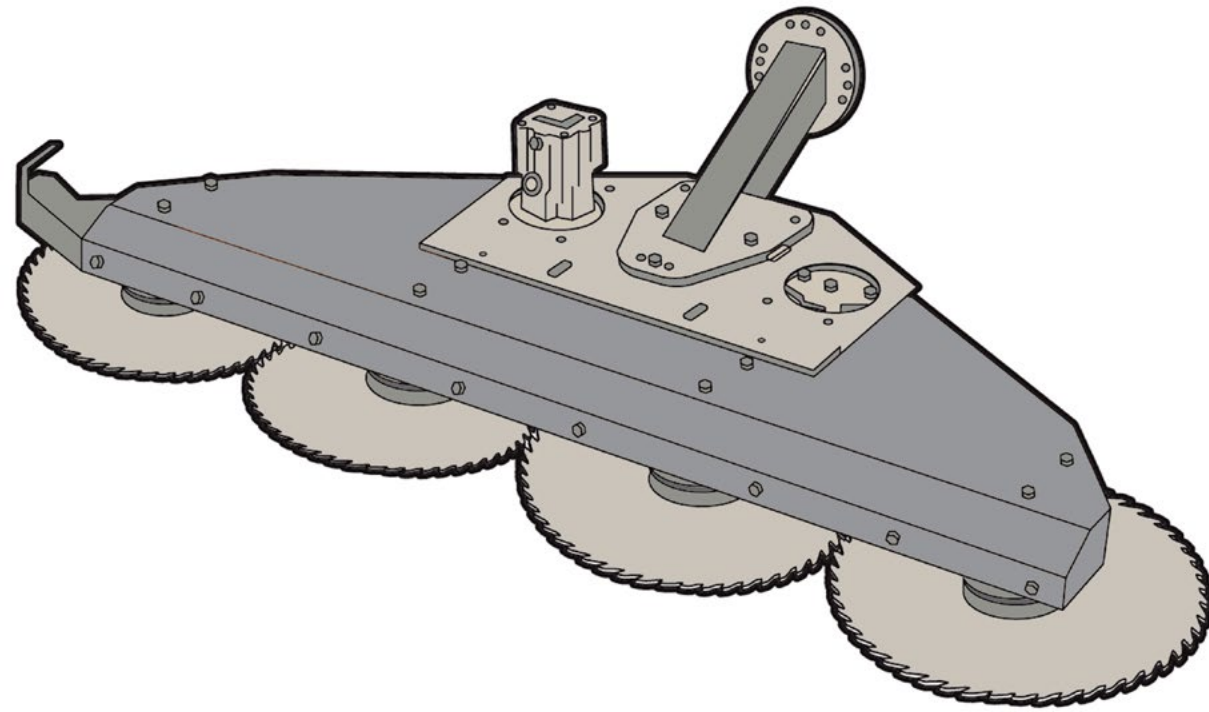

QUADSAW

MADE IN UK

STANDARD FEATURES	LOW NOISE LEVELS - HIGH SPEED BELT DRIVE - TUNGSTEN CARBIDE TIPPED BLADES
AVAILABLE OPTIONS	MANUAL QUICK RELEASE KIT - HYDRAULIC QUICK RELEASE KIT - <i>TRISAW ALSO AVAILABLE - (3 CIRCULAR SAW BLADES)</i>
TRACTOR REQUIREMENTS	MULTI-PURPOSE HYDRAULIC POWER ARM (BOOM ARM) PAR-320-01

MODEL	MSH-058-01
CUTTING WIDTH	6'5" (2 m)
NUMBER OF BLADES	4 CIRCULAR SAW BLADES
CUTTING CAPACITY	5.9" (150 mm)
MINIMUM FLOW	22.19 gpm - 22.98 gpm (84 L /min - 87 L /min)
PRESSURE	3191 psi (220 bar)

SPECIAL APPLICATIONS

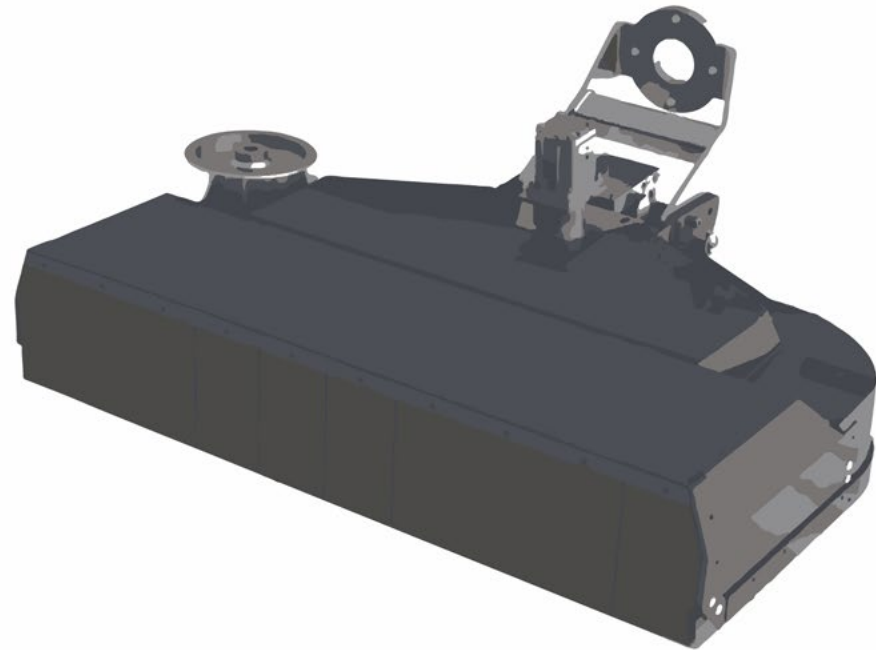

ROTARY FINISHING HEAD

MADE IN UK

STANDARD FEATURES	BRANCH GUIDE - FRONT RUBBER FLAP - HIGH SPEED BELT DRIVE - (6) BLADE X (3) ROTOR FINE CUT CUTTING SYSTEM
AVAILABLE OPTIONS	MANUAL QUICK RELEASE KIT - HYDRAULIC QUICK RELEASE KIT
TRACTOR REQUIREMENTS	MULTI-PURPOSE HYDRAULIC POWER ARM (BOOM ARM) PAR-320-01

MODEL	MRH-050-01
CUTTING WIDTH	4'2" (1.3 m)
NUMBER OF BLADES	18
CUTTING CAPACITY	1.81" (30 mm)
MINIMUM FLOW	11.88 gpm (45 L /min)
PRESSURE	2610 psi (180 bar)

SPECIAL APPLICATIONS

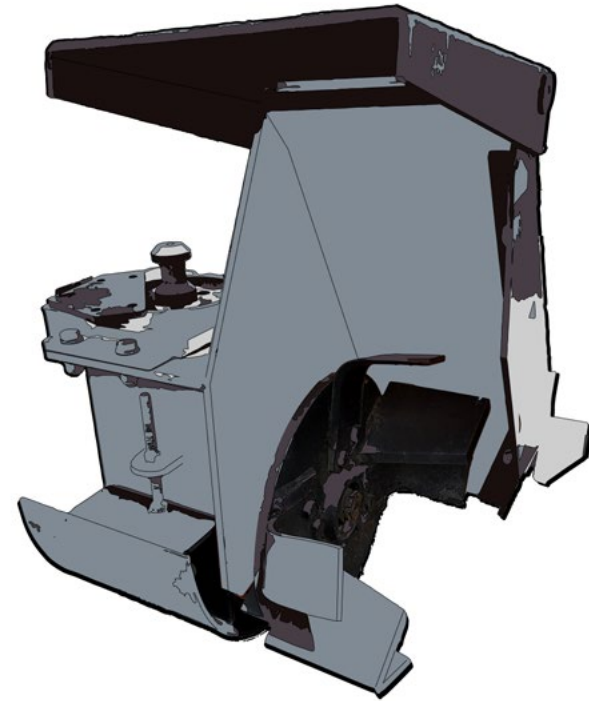

DITCH DIGGER

MADE IN EU

STANDARD FEATURES	QUICK CHANGE SYSTEM - ADJUSTABLE DISCHARGE CENTER
TRACTOR REQUIREMENTS	MULTI-PURPOSE HYDRAULIC POWER ARM (BOOM ARM) PAR-157-XX

MODEL	DDH-020-01
OIL QUANTITY REQUIRED	15.85 gpm @ 2900 psi (60 L /min @ 200 bar)
CUTTING DISC DIAMETER	19.68" (500 mm)
NUMBER OF BLADES	4
WEIGHT	286 lb (129 kg)

SPECIAL APPLICATIONS

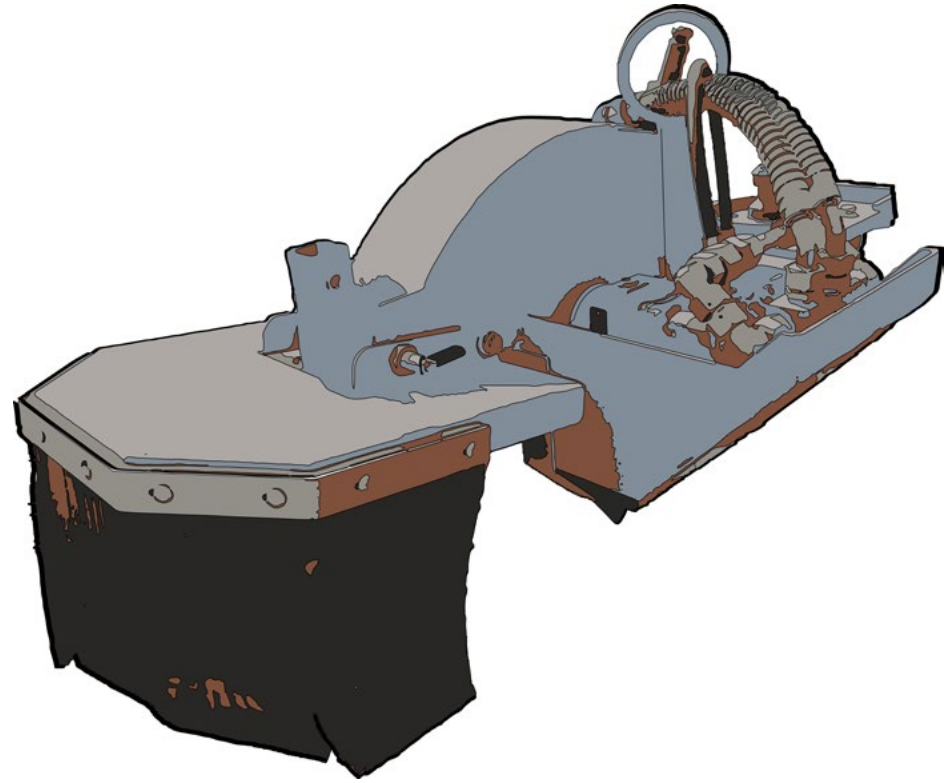

STUMP GRINDER

MADE IN EU

STANDARD FEATURES

QUICK CHANGE SYSTEM -
DRIVE VIA AXIAL PISTON ENGINE -
ROBUST TRANSMISSION GEAR (w/out CHAIN)

TRACTOR REQUIREMENTS

MULTI-PURPOSE HYDRAULIC POWER ARM (BOOM ARM)
PAR-157-XX

MODEL	SGH-021-01
MILLING DISC DIAMETER	21.65" (549 mm)
NUMBER OF TEETH	20 CARBIDE TIPS
WORKING DEPTH	15.75" (400 mm)
WEIGHT	132 lb (60 kg)
POWER	33.5 HP (25 kW)
OIL QUANTITY REQUIRED	14.5 gpm @ 2900 psi (55 L /min @ 200 bar)

SPECIAL APPLICATIONS



EARTH AUGER

MADE IN EU

STANDARD FEATURES

QUICK CHANGE SYSTEM -
w/ ONE PIECE AUGER - EXISTING DRILLS CAN BE USED -
DRILL CONNECTION STIHL DRILL BT 360

TRACTOR REQUIREMENTS

MULTI-PURPOSE HYDRAULIC POWER ARM (BOOM ARM)
PAR-157-XX

MODEL	EAH-028-01
DRILLING DEPTH	27" (700 mm)
OIL QUANTITY REQUIRED	15.85 gpm @ 2900 psi (60 L /min @ 200 bar)
DIAMETER	5.9" (150 mm)
WEIGHT	132 lb (60 kg)
SPEED	200 min-1
TORQUE	300 Nm
CAPACITY	14 HP (11 kW)

SPECIAL APPLICATIONS



POST BRUSHES

MADE IN EU

STANDARD FEATURES

QUICK CHANGE SYSTEM -
 WATER SUPPLY ACTIVATED BY TURNING THE BRUSHES -
 STAINLESS STEEL SPLASH GUARD MOUNT w/ INTERNAL WATER SUPPLY -
 WATER HOSES AND COUPLINGS -
 2 LEVEL ROTATABLE HEAD SETTING ENABLES THE WASHING OF CRASH BARRIERS, REFLECTOR POSTS AND TRAFFIC SIGNS

TRACTOR REQUIREMENTS

MULTI-PURPOSE HYDRAULIC POWER ARM (BOOM ARM)
PAR-157-XX

MODEL	PWH-019-01
BRUSH DIAMETER	15.74" (400 mm)
BRUSH LENGTH	20.47" (520 mm)
REQUIRED PUMP	4.54 gpm - 6.8 gpm @ 4351 psi (10 L /min - 15 L /min @ 300 bar)
WEIGHT	165 lb (74.84 kg)

SPECIAL APPLICATIONS

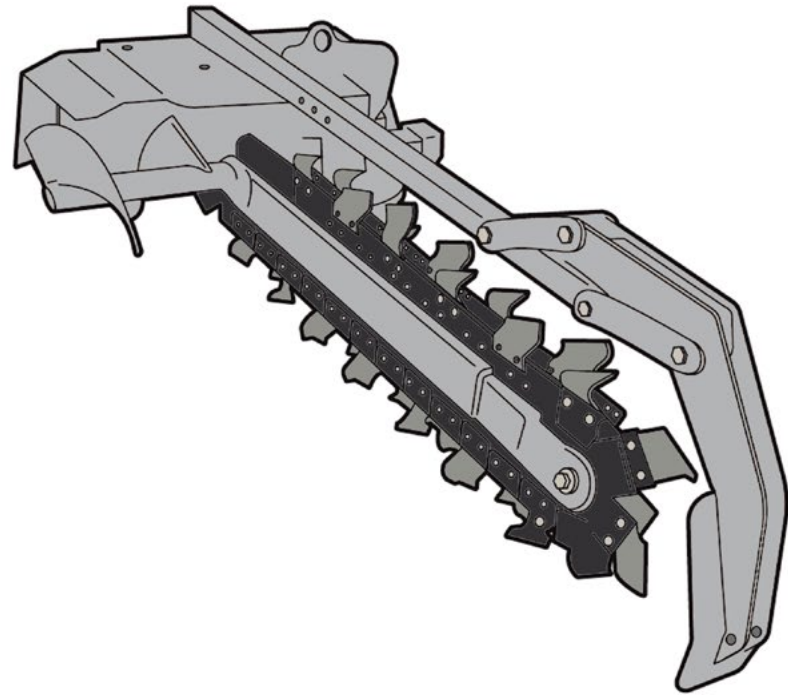

TRENCH AXE

MADE IN UK

STANDARD FEATURES	SIDE AUGER - HEAVY DUTY SOLID STEEL NOSE - ADJUSTABLE CHAIN TENSION - CRUMB SCRAPER BAR
AVAILABLE OPTIONS	BULLET TOOTH CHAIN
TRACTOR REQUIREMENTS	3-POINT HITCH EXTERNAL CONTROL

MODEL	TRA-036-01
TRENCHER DEPTH	36" (914 mm)
TRENCHER WIDTH	4" - 6" (101 mm - 152 mm)
WEIGHT	810 lb (367 kg)
MAIN SHAFT SIZE	2 - 9/16" SOLID HARDENED STEEL
OVER TORQUE PROTECTION	HYDRAULIC RELIEF
DRIVE TYPE	PLANETARY
POWER REQUIREMENTS	40 HP - 100 HP (30 kW - 74 kW)
TRACTOR FIT (HOLDER)	C992 - S100 - S130

SPECIAL APPLICATIONS

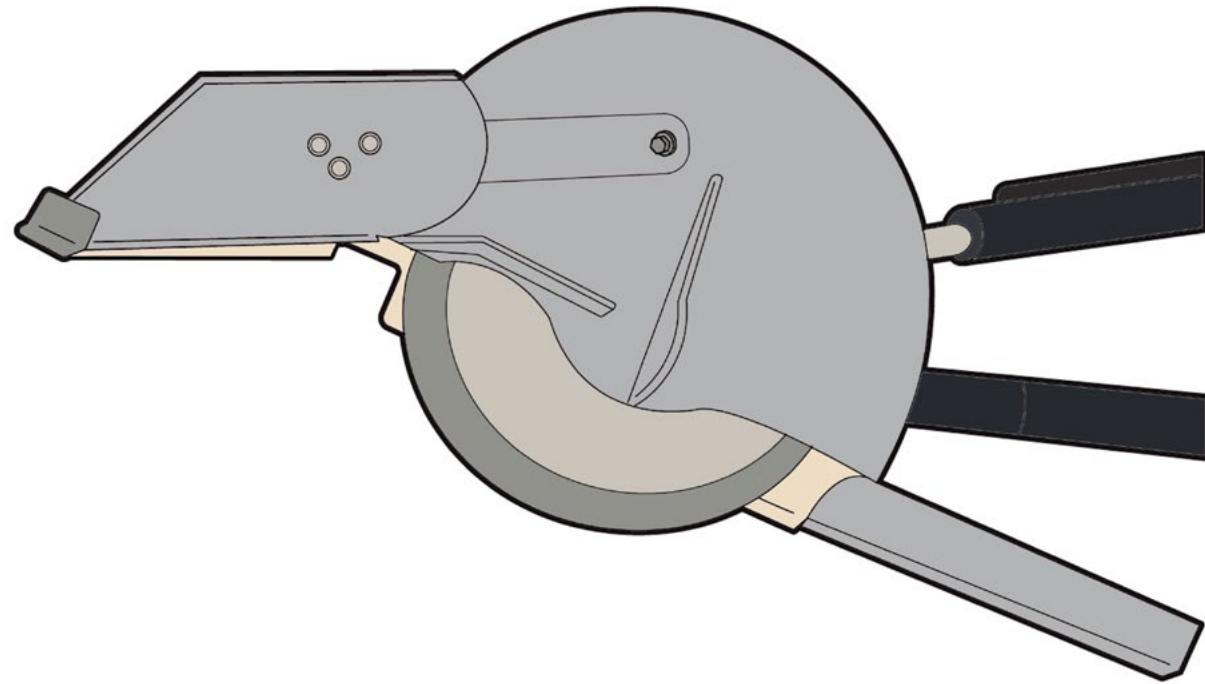

STUMP GRINDER

MADE IN UK

STANDARD FEATURES	FLOW CONTROL CUTTING PASS SPEED - RUGGED GEARBOX - BOLT-ON TEETH DESIGN - HEAVY DUTY STABILIZER BASE - FLOATING DEFLECTOR
AVAILABLE OPTIONS	EXTERNAL CONTROL
TRACTOR REQUIREMENTS	CAT II (3-POINT HITCH)

MODEL	STG-024-01
LENGTH	49" (1244 mm)
WIDTH	42" (1066 mm)
ROTOR SIZE	24" (609 mm)
NUMBER OF TEETH	34
TOOTH CONSTRUCTION	S1000
CUTTING WHEEL SPEED	810 RPM
CUTTING HEIGHT	18" (457 mm) (ABOVE GROUND)
CUTTING DEPTH	8" (203 mm) (BELOW GROUND)
SWING ARC	65°
WEIGHT	624 lb (283 kg)
MAX. ENGINE HP	65 HP (48 kW)
MAX. PTO HP	55 HP (41 kW)
POWER REQUIREMENTS	25 HP - 55 HP (18 kW - 41 kW)
TRACTOR FIT (HOLDER)	C270 - C70 - C992 - S100 - S130

SPECIAL APPLICATIONS

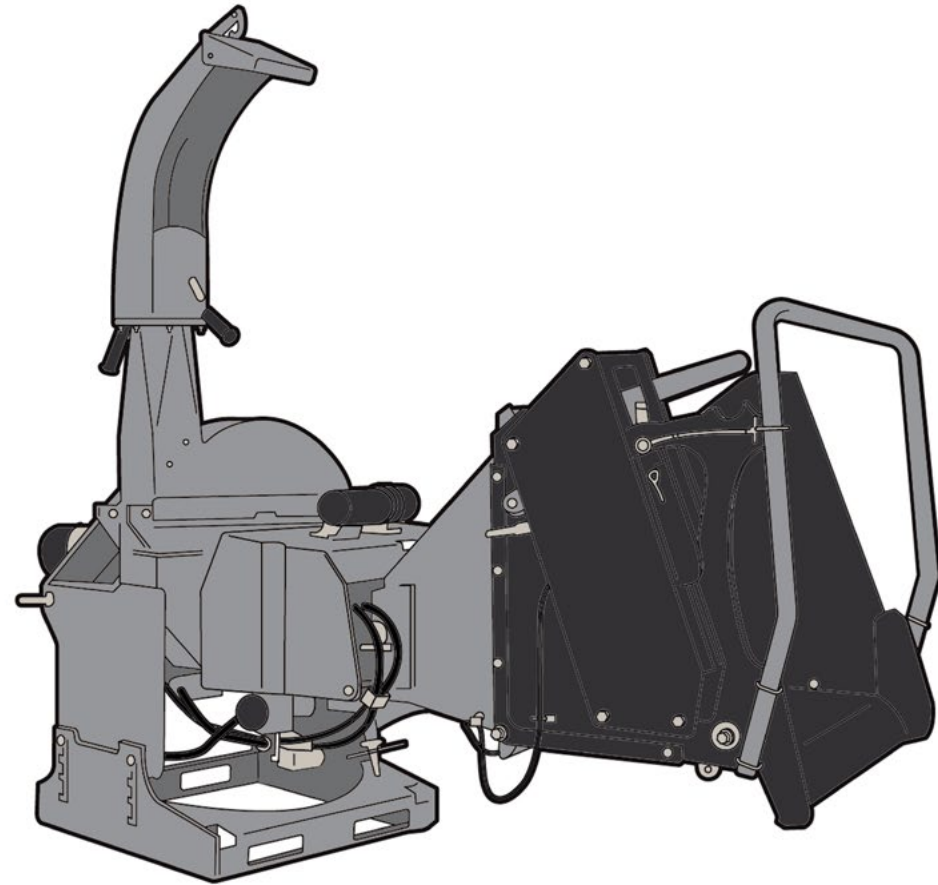

MADE IN CANADA

WOOD CHIPPER

STANDARD FEATURES	360° ADJUSTABLE CHUTE - ADJUSTABLE SKI BASE - DUAL ACTIVE ROLLERS - FOLD UP FEED HOPPER - SAFETY CONTROL BAR - SHEARBOLT PROTECTED PTO DRIVETRAIN
AVAILABLE OPTIONS	REVERSIBLE ROTOR KNIVES
TRACTOR REQUIREMENTS	CAT II QUICK HITCH COMPATIBLE

MODEL	WCH-005-01
LENGTH	80" (2032 mm) OPEN 62" (1575 mm) FOLDED
WIDTH	67" (1702 mm) OPEN 61" (1549 mm) FOLDED
HEIGHT	74" (1879 mm) OPEN 74" (1879 mm) FOLDED
CHIPPING CAPACITY	5" (127 mm)
DRIVE SYSTEM	PTO DIRECT DRIVE
WEIGHT	845 lb (383 kg)
CHIPPER TYPE	DISC
FEED SYSTEM	DUAL HYDRAULIC ROLLER FEED
NUMBER OF CHIPPER KNIVES	4
DISCHARGE CHUTE ROTATION	360°
RPM	540 - 1000
HYDRAULIC FLOW	3 gpm - 6 gpm (12 L /min - 23 L /min)
POWER REQUIREMENTS	40 HP - 55 HP (30 kW - 41 kW)
TRACTOR FIT (HOLDER)	C270 - C70 - C992 - S100 - S130

SPECIAL APPLICATIONS

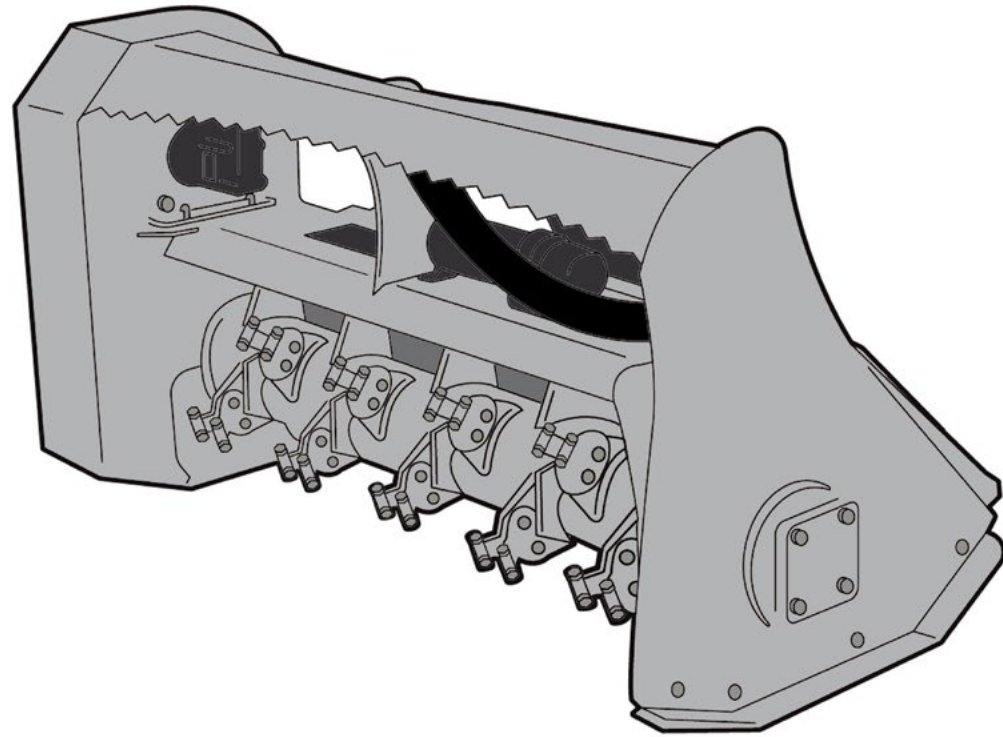

MADE IN CANADA

HEAVY DUTY MULCHER

STANDARD FEATURES	INTEGRATED BRUSH BAR - INTEGRATED SKID SHOES - HIGH SPEED TEETH - SPIRAL TOOTH PATTERN - HEAVY DUTY GEARBOX - REINFORCED BELT - POWDER COAT WIRE PROTECTION KIT - SLIP CLUTCH PROTECTION
TRACTOR REQUIREMENTS	CAT II (3-POINT HITCH)

MODEL	HDM-060-01
PATH WIDTH	60" (1524 mm)
ROTOR WIDTH	48" (1219 mm)
CUTTING STYLE	HIGH SPEED TEETH
NUMBER OF TEETH	60
ROTOR SHAFT SIZE	2" (51 mm)
ROTOR DIAMETER	15" (381 mm)
WEIGHT	1050 lb (476 kg)
RPM	1800
DRIVE SPEED	540 RPM
POWER REQUIREMENTS	25 HP - 50 HP (18 kW - 37 kW)
TRACTOR FIT (HOLDER)	C992 - S100 - S130

SPECIAL APPLICATIONS

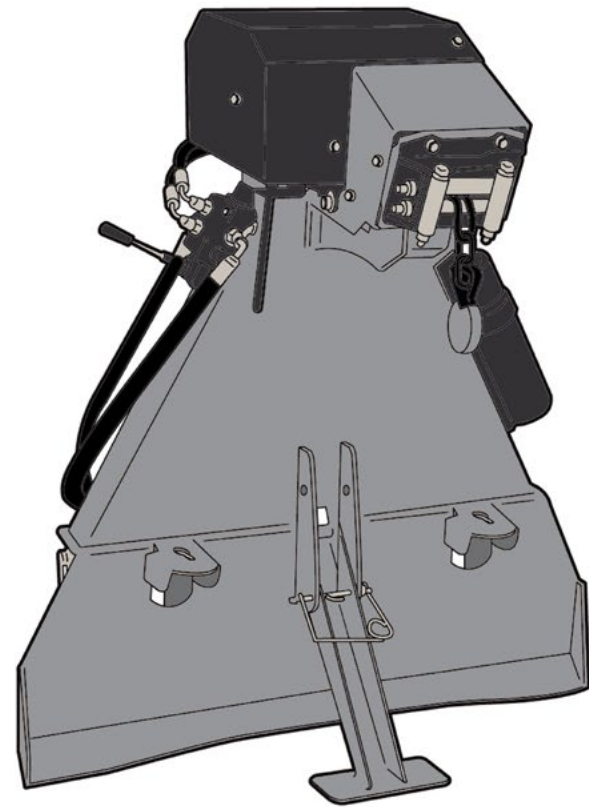

MADE IN CANADA

SKIDDING WINCH

STANDARD FEATURES	2 CHOKER CHAINS - 2 KEY HOLE SLIDERS - TOW BAR - TRAILER HITCH - REMOVABLE CLUTCH ASSEMBLY - SNATCH BLOCK PULLEY SYSTEM - ROPE CONTROLLED BRAKE/CLUTCH SYSTEM - SHEARBOLT PROTECTED PTO DRIVETRAIN
AVAILABLE OPTIONS	60" (1524 mm) or 84" (2133 mm) SYNTHETIC CHOKER - 90" (2286 mm) CHOKER CHAIN - LOGGING TONGS - NYLON CHAINSAW HOLDER - SELF-RELEASING DIRECTIONAL PULLEY - SYNTHETIC ROPE
TRACTOR REQUIREMENTS	CAT I CAT II

MODEL	SKW-080-01
LENGTH	28" (711 mm)
WIDTH	51" (1295 mm)
HEIGHT	79" (2006 mm)
PULLING CAPACITY	11,000 lb (4989 kg)
WINCH TYPE	MECHANICAL DRY DISC CLUTCH
LINE SPEED	98 ft-min - 253 ft-min (30 m /min - 77 m /min)
CABLE TYPE	STEEL
CABLE LENGTH	165' (50 m)
CABLE DIAMETER	7/16" (11 mm)
CHOKER CHAINS	2
PTO INPUT SPEED	540 RPM
WEIGHT	796 lb (361 kg)
POWER REQUIREMENTS	50 HP - 90 HP (37 kW - 67 kW)
TRACTOR FIT (HOLDER)	C270 - C70 - C992 - S100 - S130

SPECIAL APPLICATIONS

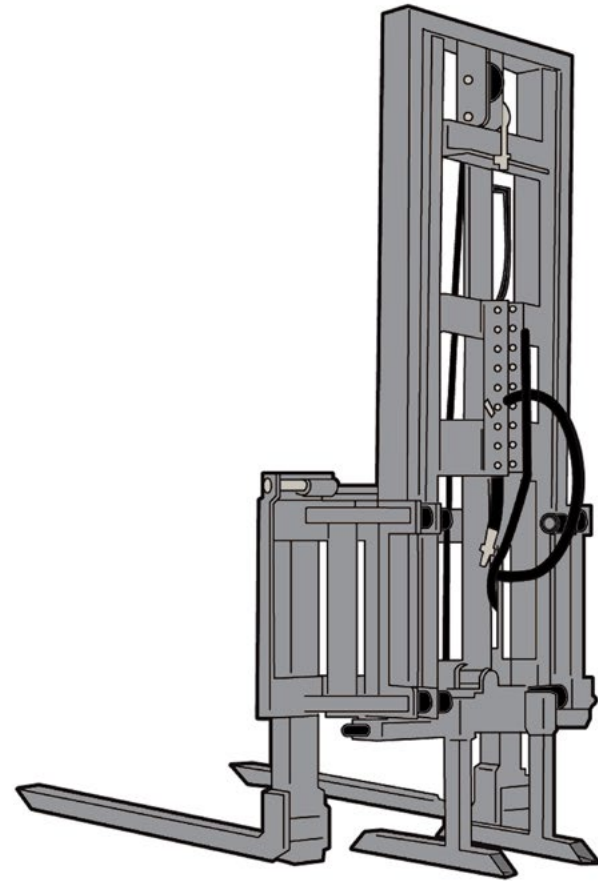

MADE IN CANADA

FORK LIFT

STANDARD FEATURES	EQUIPPED w/ FOLDING LINES
AVAILABLE OPTIONS	60" (1524 mm) HOSE KITS w/ PIONEER COUPLINGS
TRACTOR REQUIREMENTS	2 SETS OF HYDRAULIC QUICK COUPLERS (DOUBLE ACTING) - CAT II

MODEL	FKL-059-01
LIFT CAPACITY	3500 lb (1587 kg)
LIFT HEIGHT	59" (1498 mm)
RETRACTED HEIGHT	65" (1651 mm)
TRACTOR FIT (HOLDER)	S75 - S100 - S130

SPECIAL APPLICATIONS

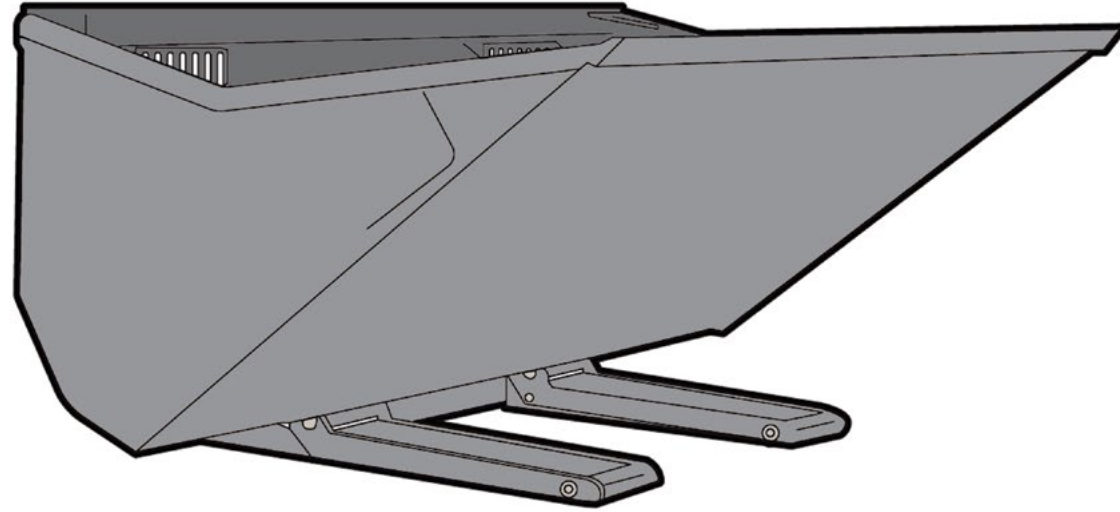

LOADER BUCKET

MADE IN CANADA

STANDARD FEATURES

EXTREMELY ROBUST BULK BUCKET FOR INDUSTRIAL APPLICATIONS -
 DOUBLE HINGE DEVICE FOR A MINIMUM OF LOSS IN DUMP HEIGHT -
 ALL ROTATING POINTS HAVE BEARINGS -
 ROUND EDGE TO PREVENT DAMAGE
 COMPLETE w/ HYDRAULIC HOSES AND QUICK CONNECTORS

TRACTOR REQUIREMENTS

REQUIRES FORK LIFT (**FKL-059-01**)

MODEL	LOA-030-01
LENGTH OF FORKS	36" (914 mm)
WORKING HEIGHT	90" (2286 mm)
HEIGHT	42" (1066 mm)
BUCKET CAPACITY	0.3 cu yard (229 L)
TRACTOR FIT (HOLDER)	S75 - S100 - S130