

# ATTACHMENT CATALOGUE

# BRINE SPRAYER

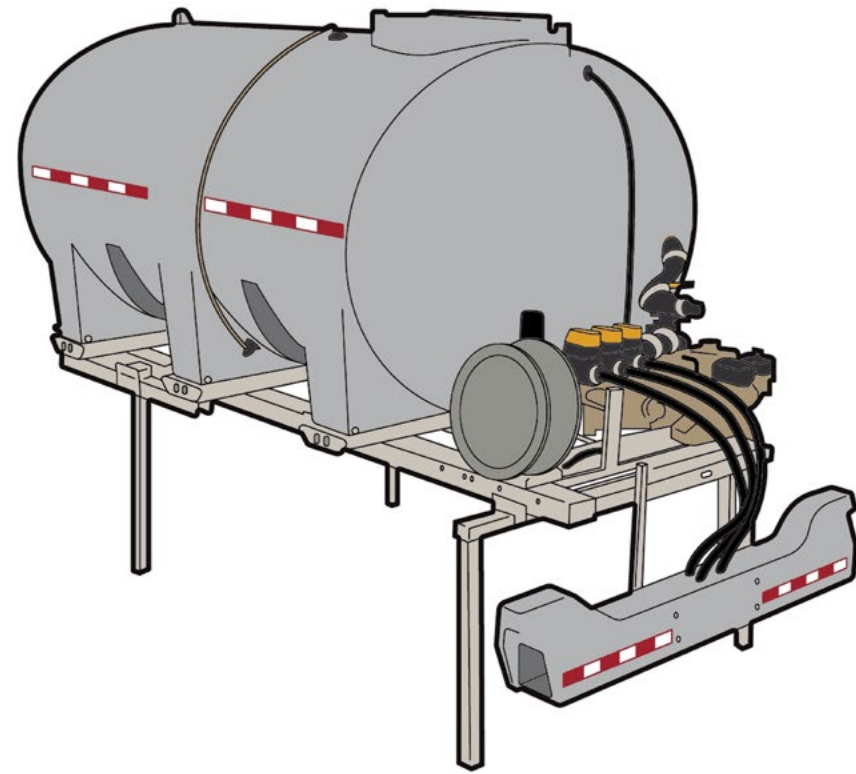

MADE IN CANADA

## BRINE SPRAYER

<b>STANDARD FEATURES</b>	DOUBLE SPRAY BAR SYSTEM - BAFFLE BALL SURGE CONTROL - FAST FILL SYSTEM - TRI-ZONE SPRAY SELECTION - AUTO DRAIN SUMP BASE - BUILT-IN FORK SLOTS - RUST ARMOUR STAINLESS FRAME
<b>AVAILABLE OPTIONS</b>	STORAGE STANDS - LIGHTS - SECURING BAR - PUMP OPTIONS: HIGH FLOW 12-VOLT, GAS or HYDRAULIC
<b>TRACTOR REQUIREMENTS</b>	OVER-ENGINE PLATFORM

MODEL	BSP-250-75
<b>TOTAL VOLUME</b>	250 gal (946 L)
<b>LENGTH</b>	81" (2057 mm)
<b>WIDTH</b>	48" (1219 mm)
<b>HEIGHT</b>	39" (991 mm)
<b>WEIGHT (EMPTY)</b>	475 lb (215 kg)
<b>FRAME TYPE</b>	STAINLESS STEEL
<b>HOSE LENGTH</b>	100' (30 m)
<b>MOUNTING</b>	4 TIE-DOWN SLOTS
<b>TANK TYPE</b>	SINGLE-PIECE ROTO MOLD HDPE
<b>SPRAY GUN TYPE</b>	ADJUSTABLE JET/FAN
<b>POWER REQUIREMENTS</b>	70 HP - 130 HP (52 kW - 97 kW)
<b>TRACTOR FIT (HOLDER)</b>	S75 - S100 - S130

# SWEEPERS

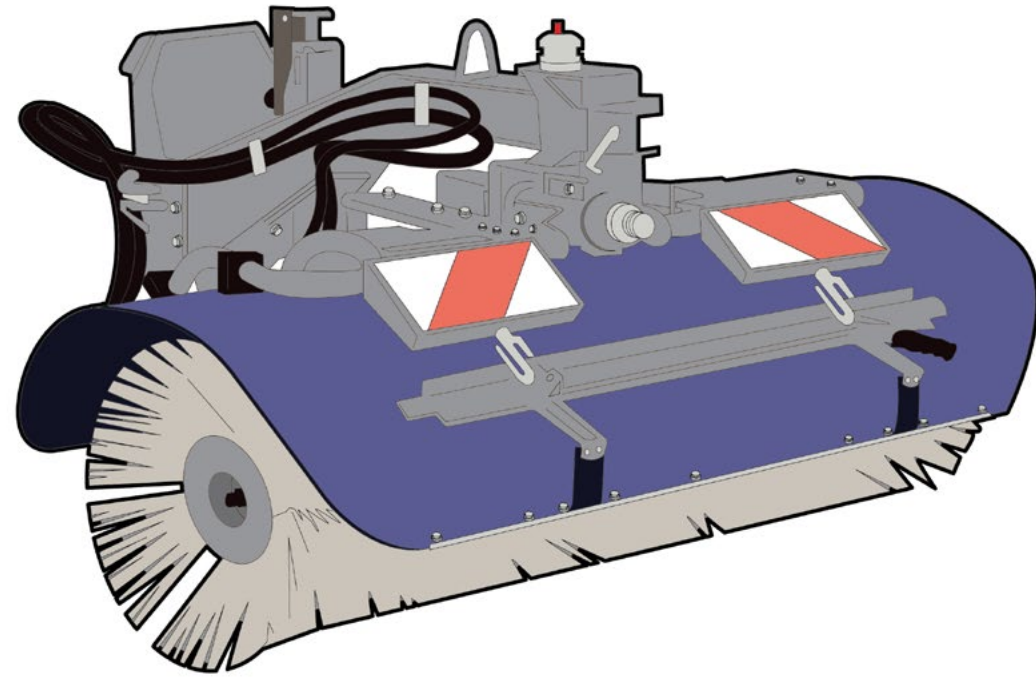

## HYDRAULIC SWEEPER - CENTRE DRIVEN

MADE IN EU

<b>STANDARD FEATURES</b>	FLAT-FACE COUPLINGS - HOLDER C250-C270 ADAPTOR PLATE - ADJUSTABLE BROOM COVER - <b>ONLY FOR SCD-059-01: CASTOR WHEEL</b>
<b>AVAILABLE OPTIONS</b>	<b>ONLY FOR SCD-059-01: WET-KIT (SPRAY NOZZLES - ELECTRICAL PUMP) (REGULAR WATER TANK IS REQUIRED)</b>
<b>TRACTOR REQUIREMENTS</b>	CAT I   (3-POINT HITCH) - 1 SET OF HYDRAULIC QUICK COUPLERS (DOUBLE ACTING) <b>ONLY FOR SCD-059-01: CAT II (IN ADDITION)</b>

MODEL	SCD-055-01	SCD-059-01
<b>TOTAL WIDTH</b>	57" (1447 mm)	61" (1550 mm)
<b>CLEARING WIDTH STRAIGHT</b>	55" (1400 mm)	59" (1500 mm)
<b>CLEARING WIDTH ANGLED</b>	59" (1500 mm) at 26°	63" (1600 mm) at 32°
<b>TURNING ANGLE (L/R)</b>	26°	32°
<b>OSCILLATION</b>	NO	18°
<b>TRANSPORT HEIGHT</b>	29" (735 mm)	41" (1050 mm)
<b>BRUSH DIAMETER</b>	21.6" (550 mm)	23.6" (600 mm)
<b>BRUSH MATERIAL</b>	POLYPROPYLENE	
<b>WEIGHT</b>	260 lb (118 kg)	529 lb (240 kg)
<b>TORQUE TO THE SHAFT</b>	147 lb*f (200 Nm)	479 lb*f (650 Nm)
<b>POWER REQUIREMENTS</b>	FLOW DIVIDER 1 OR HIGH FLOW PUMP 6.6 gpm (25 L /min)	HIGH FLOW PUMP 10 gpm (40 L /min)
<b>TRACTOR FIT (HOLDER)</b>	C70 - C270 - C992 - S75	C70 - C270 - C992 - S75 - S100 - S130

# SWEEPERS

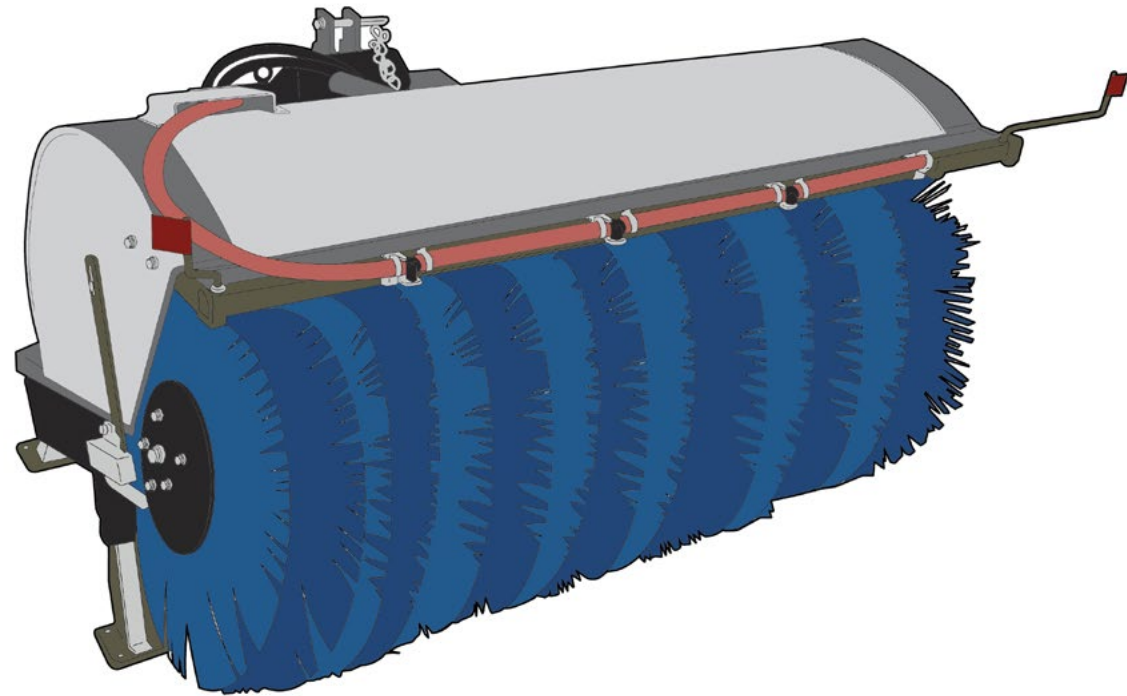

## PTO DRIVEN SWEEPER WITHOUT WET KIT

MADE IN CANADA

<b>STANDARD FEATURES</b>	PU COWLING - PARKING LEGS - POLY STEEL COMBINATION BRUSHES - WATER SPRAY BAR - WATER PUMP - ADAPTER PLATE FOR WHEEL KIT
<b>AVAILABLE OPTIONS</b>	STAINLESS STEEL OR STEEL COWLING - WHEEL KIT HYDRAULIC DRIVEN MODELS AVAILABLE
<b>TRACTOR REQUIREMENTS</b>	CAT I   CAT II (3-POINT HITCH)

MODEL	SPT-048-02	SPT-060-02	SPT-072-02
<b>TOTAL WIDTH</b>	53" (1346 mm)	65" (1651 mm)	77" (1955 mm)
<b>CLEARING WIDTH STRAIGHT</b>	48" (1219 mm)	60" (1524 mm)	72" (1828 mm)
<b>CLEARING WIDTH ANGLED 30°</b>	42" (1066 mm)	52" (1320 mm)	62" (1574 mm)
<b>HEIGHT</b>	38" (965 mm)		
<b>BRUSH DIAMETER</b>	32" (812 mm)		
<b>SWING ANGLE</b>	30°		
<b>DRIVE ASSEMBLY</b>	SIDE DRIVE VIA GEARBOX & CHAIN		
<b>TYPE</b>	MECHANICAL		
<b>WEIGHT</b>	685 lb (310 kg)	780 lb (353 kg)	860 lb (390 kg)
<b>POWER REQUIREMENTS</b>	40 HP (30 kW)		
<b>TRACTOR FIT (HOLDER)</b>	C70 - C270	C70 - C270 - C992 - S75 - S100 - S130	C992 - S75 - S100 - S130

# SWEEPERS

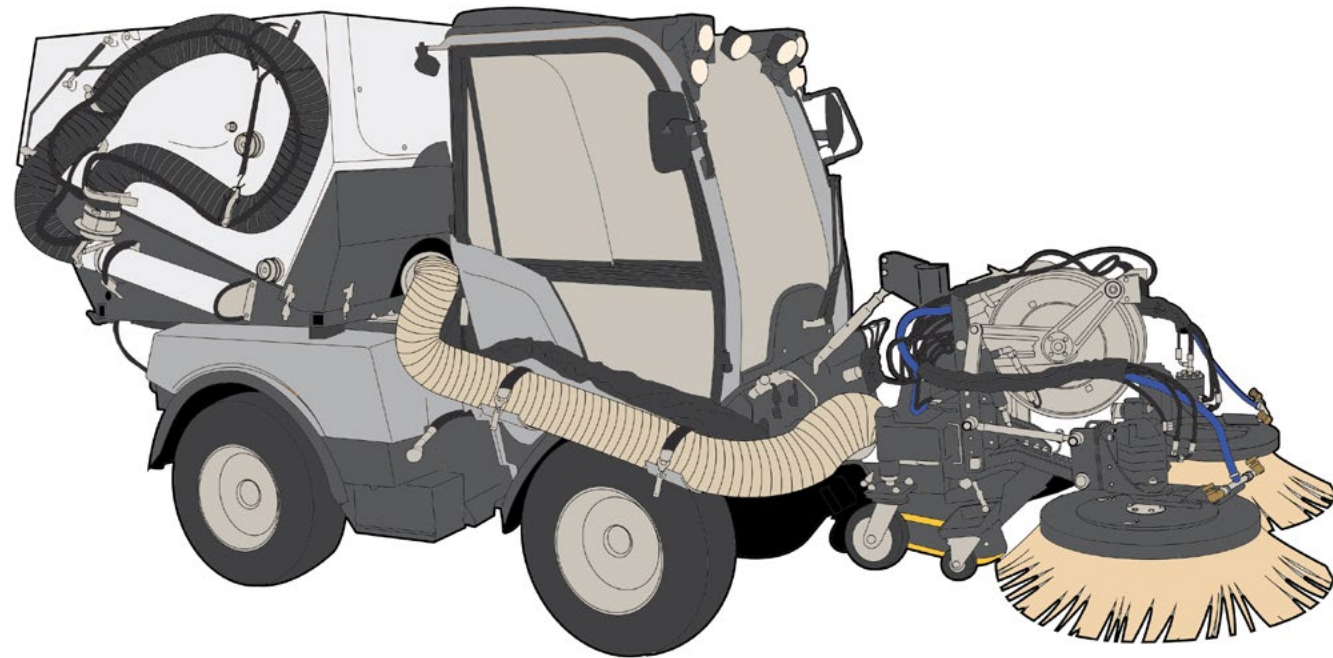

## VACUUM SWEEPER

MADE IN EU

<b>STANDARD FEATURES</b>	ROBUST ALUMINUM CONTAINER - REDUCED NOISE OUTPUT - REDUCED FUEL CONSUMPTION - REAR VIEW CAMERA - HAND-HELD SUCTION HOSE
<b>AVAILABLE OPTIONS</b>	RIGHT OR LEFT HAND BRUSH OPTIONS ARE AVAILABLE AS A WEED BRUSH w/ HYDRAULIC INCLINATION ADJUSTMENT

MODEL	SVC-072-02	SVC-200-01
<b>HOPPER (GROSS)</b>	1.57 cu yard (1.2 m <sup>3</sup> )	2.1 cu yard (1.6 m <sup>3</sup> )
<b>HOPPER (NET)</b>	1.05 cu yard (0.8 m <sup>3</sup> )	1.56 cu yard (1.19 m <sup>3</sup> )
<b>FRESH WATER TANK</b>	58 gal (219 L)	74 gal (280 L)
<b>RECYCLED WATER</b>	approx. 40 gal (151 L)	up to 137 gal (518 L)
<b>TOTAL HEIGHT</b>	from 84" (2133 mm)	approx. 90" (2286 mm)
<b>TOTAL OUTER WIDTH</b>	from 44" (1117 mm)	approx. 63" (1600 mm)
<b>PLATE BRUSH DIAMETER</b>	33" (838 mm)	
<b>SWEEPING WIDTH SUCTION MOUTH</b>	78" (1981 mm)	
<b>POWER REQUIREMENTS</b>	45 HP - 74 HP (33 kW - 55 kW)	70 HP - 130 HP (52 kW - 97 kW)
<b>TRACTOR FIT (HOLDER)</b>	C70 - C270	S75 - S100 - S130

# STEAM CLEANER

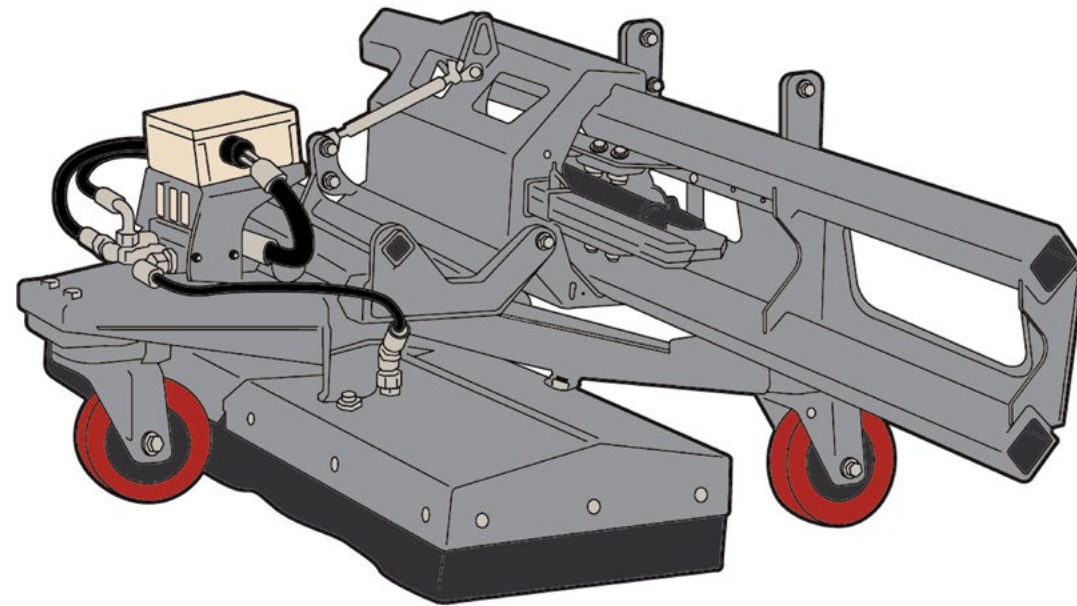

## HOT WATER WEED KILLER

MADE IN EU

<b>STANDARD FEATURES</b>	SPECIAL HOT WATER NOZZLES FOR HOMOGENEOUS APPLICATION - STORAGE VIA A MAINTENANCE-FREE SPRING ELEMENT - AN IMPELLER FOR OPTIMAL GROUND-SURFACE ADAPTATION - TILT ADJUSTMENT - STORAGE CART w/ WHEELS FOR EASY MOUNTING
<b>AVAILABLE OPTIONS</b>	LATERAL NOZZLES (MOUNTING ON BOTH SIDES POSSIBLE)
<b>TRACTOR REQUIREMENTS</b>	OIL DEMAND 1.3 gpm (5 L /min)

MODEL	HWK-317-01
<b>LENGTH</b>	30" (770 mm)
<b>TOTAL WIDTH</b>	47" (1200 mm)
<b>WORKING WIDTH</b>	39" (1000 mm)
<b>HEIGHT</b>	23" (540 mm)
<b>WEIGHT</b>	132 lb (60 kg)
<b>UNIT MATERIAL</b>	STAINLESS STEEL V2A
<b>POWER REQUIREMENTS</b>	45 HP - 130 HP (33 kW - 97 kW)
<b>TRACTOR FIT (HOLDER)</b>	C70 - C270 - C992 - S75 - S100 - S130

# MOWERS

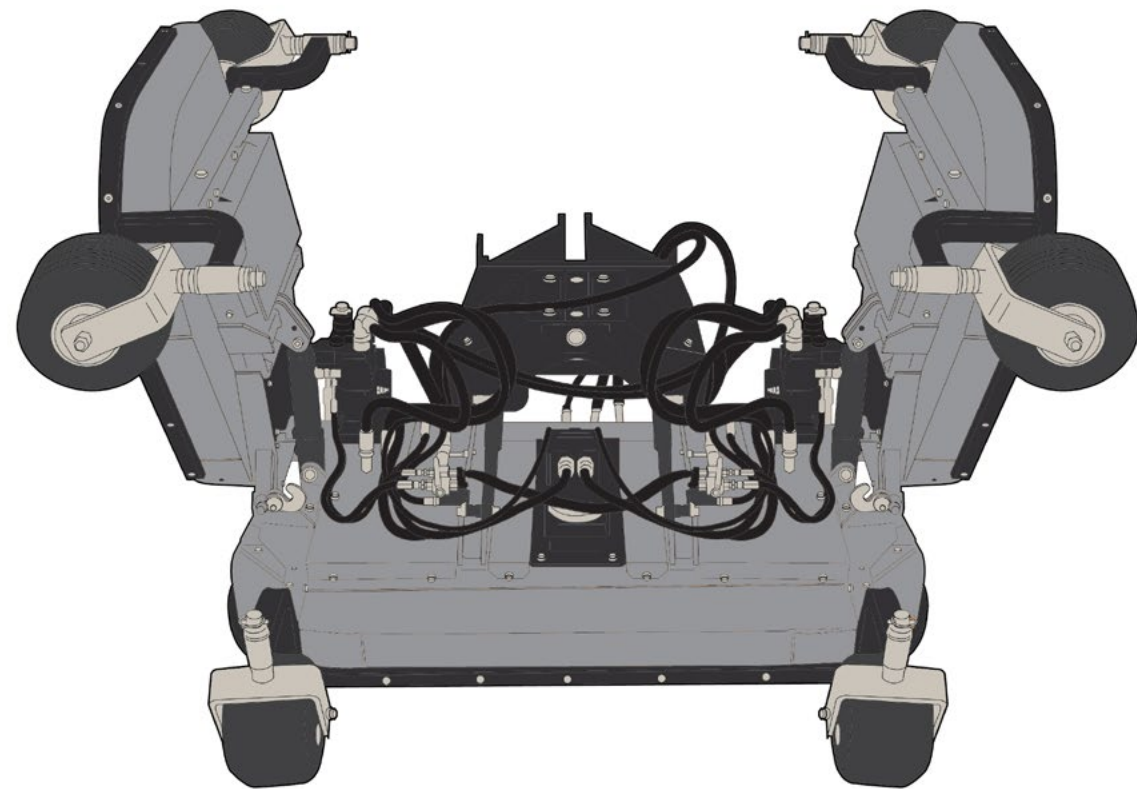

## HYDRAULICALLY DRIVEN TRI-DECK ROTARY MOWER

MADE IN EU

<b>STANDARD FEATURES</b>	MECHANICAL TILT UP - AUTOMATIC SHUT-OFF OF THE SIDE WINGS WHEN RAISED MORE THAN 15" (400 mm) - CUT 10° BELOW LEVEL AND 15° ABOVE (WHEN FLOATED) - HYDRAULIC TRANSMISSION VIA DIRECT DRIVE
<b>AVAILABLE OPTIONS</b>	HYDRAULIC TILT UP MECHANICAL MAIN DECK
<b>TRACTOR REQUIREMENTS</b>	CAT I   CAT II - 3 POINT HITCH - 2 SETS OF HYDRAULIC QUICK COUPLINGS (DOUBLE ACTING) w/ FLOAT MODE - HIGH-FLOW PUMP - COUNTERWEIGHT - TURF TIRES

MODEL	MTD-098-02	MTD-114-02
<b>LARGEST WIDTH</b>	100" (2535 mm)	117" (2975 mm)
<b>TRANSPORT WIDTH</b>	69" (1750 mm)	79" (2000 mm)
<b>LARGEST LENGTH</b>	61" (1550 mm)	65" (1655 mm)
<b>LARGEST HEIGHT</b>	20" (500 mm)	
<b>TRANSPORT HEIGHT</b>	32" (820 mm)	36" (920 mm)
<b>CUTTING WIDTH</b>	98" (2480 mm)	114" (2900 mm)
<b>CUTTING HEIGHT</b>	1" - 3" (30 mm - 80 mm)	
<b>NECESSARY FLOW</b>	16 gal @ 3625 psi (60 L /min @ 250 bar)	18 gal @ 3625 psi (70 L /min @ 250 bar)
<b>NUMBER OF ROTORS</b>	5	
<b>NUMBER OF KNIVES</b>	5 x 21" (533 mm)	5 x 24" (620 mm)
<b>TIRES</b>	AIR RUBBER TIRES (6) 10" x 3"	
<b>WEIGHT</b>	804 lb (365 kg)	970 lb (440 kg)
<b>POWER REQUIREMENTS</b>	34 HP (25 kW)	41 HP (30 kW)
<b>TRACTOR FIT (HOLDER)</b>	C70 - C270	C70 - C270 - C992 - S75 - S100 - S130

# MOWERS

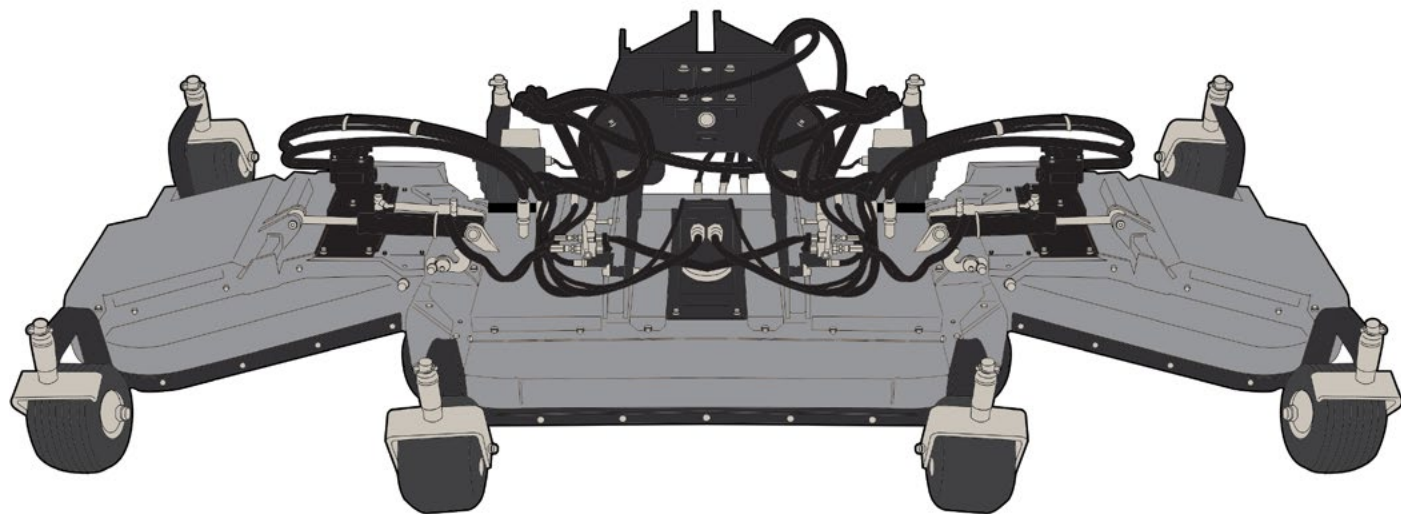

## HYDRAULICALLY DRIVEN TRI-DECK ROTARY MOWER

MADE IN EU

<b>STANDARD FEATURES</b>	MECHANICAL TILT UP - AUTOMATIC SHUT-OFF OF THE SIDE WINGS WHEN RAISED MORE THAN 15" (400 mm) - CUT 10° BELOW LEVEL AND 15° ABOVE (WHEN FLOATED) - HYDRAULIC TRANSMISSION VIA DIRECT DRIVE
<b>AVAILABLE OPTIONS</b>	HYDRAULIC TILT UP MECHANICAL MAIN DECK
<b>TRACTOR REQUIREMENTS</b>	CAT I   CAT II - 3 POINT HITCH - 2 SETS OF HYDRAULIC QUICK COUPLINGS (DOUBLE ACTING) w/ FLOAT MODE - HIGH-FLOW PUMP - COUNTERWEIGHT - TURF TIRES

MODEL	MTD-136-02	MTD-159-02
<b>LARGEST WIDTH</b>	139" (3525 mm)	162" (4120 mm)
<b>TRANSPORT WIDTH</b>	69" (1750 mm)	79" (2000 mm)
<b>LARGEST LENGTH</b>	64" (1625 mm)	68" (1735 mm)
<b>LARGEST HEIGHT</b>	24" (600 mm)	
<b>TRANSPORT HEIGHT</b>	47" (1200 mm)	57" (1450 mm)
<b>CUTTING WIDTH</b>	136" (3460 mm)	158" (4025 mm)
<b>CUTTING HEIGHT</b>	1" - 3" (30 mm - 80 mm)	
<b>NECESSARY FLOW</b>	16 gal @ 3625 psi (80 L /min @ 250 bar)	18 gal @ 3625 psi (85 L /min @ 300 bar)
<b>NUMBER OF ROTORS</b>	7	
<b>NUMBER OF KNIVES</b>	7	
<b>TIRES</b>	AIR RUBBER TIRES (8) 11" x 7" (279 mm x 177 mm)	
<b>WEIGHT</b>	1146 lb (520 kg)	1323 lb (600 kg)
<b>POWER REQUIREMENTS</b>	51 HP (37.5 kW)	56 HP (41.5 kW)
<b>TRACTOR FIT (HOLDER)</b>	C992 - S75 - S100 - S130	

# MOWERS

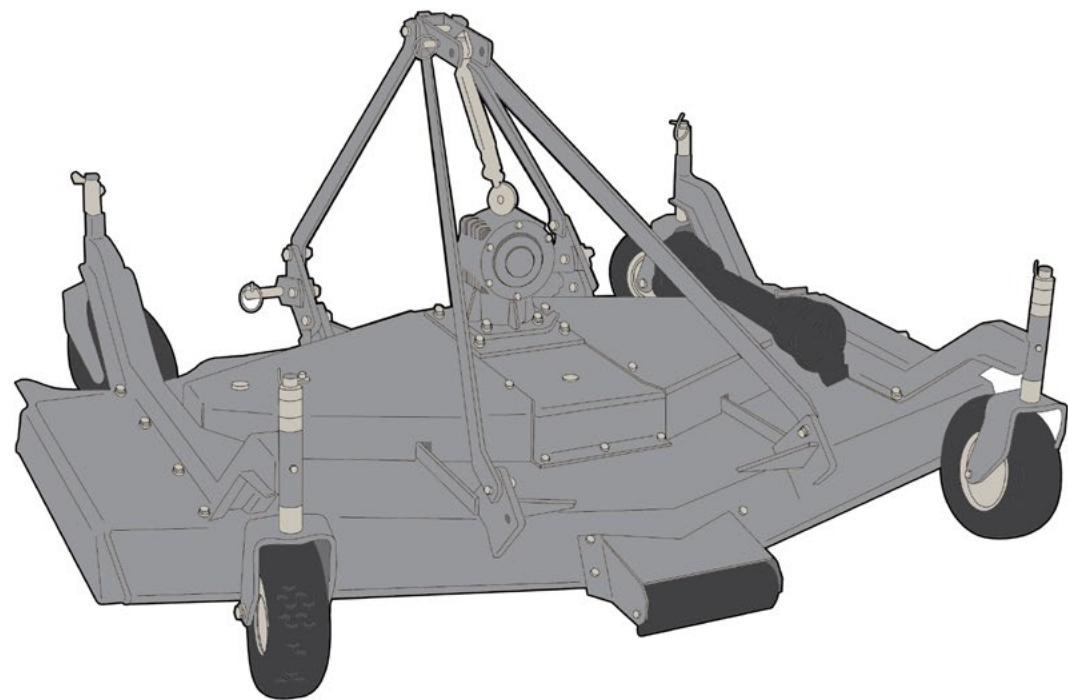

## PTO DRIVEN ROTARY MOWER DECK

MADE IN USA

<b>STANDARD FEATURES</b>	GEARBOX w/ SPIRAL GEARS - MANUAL BELT TENSIONING - STAMPED STEEL REINFORCED WHEEL ARMS - DOUBLE BELT TRANSMISSION - CAST IRON PULLEYS - AXIAL GREASE FITTINGS - 8 GAUGE REINFORCED MOWER DECK - SAFETY CHAIN SHIELD
<b>AVAILABLE OPTIONS</b>	QUICK HITCH ADAPTER - MULCHING KIT - FRONT ANTI-SCALP ROLLER - REAR ROLLER - FRONT MOUNT (FACTORY INSTALLED)
<b>AVAILABLE BLADE OPTIONS</b>	STANDARD - LOW LIFT - HIGH LIFT - MULCHING
<b>TRACTOR REQUIREMENTS</b>	540 RPM - CAT I (3-POINT HITCH) - FRONT AND REAR TRACTOR MOUNTING

MODEL	MRT-060-01	MRT-072-01	MRT-084-01
<b>WORKING WIDTH</b>	60" (1524 mm)	72" (1829 mm)	84" (2134 mm)
<b>OVERALL WIDTH</b>	62" (1575 mm)	74" (1880 mm)	86" (2184 mm)
<b>WEIGHT</b>	534 lb (242 kg)	584 lb (265 kg)	674 lb (306 kg)
<b>ROTOR RPM</b>	3210	2605	2195
<b>BLADE TIP SPEED</b>	16,929 ft /min (5160 m /min)	16,732 ft /min (5100 m /min)	16,338 ft /min (4980 m /min)
<b>NUMBER OF BLADES</b>	3		
<b>CUTTING HEIGHT</b>	1" - 5" (25 mm - 127 mm)		
<b>NUMBER OF BELTS &amp; TYPE</b>	2 SPBX		
<b>DRIVELINE 1 3/8"</b>	ASAE CAT 3		
<b>TIRES</b>	PNEUMATIC (4) 11" x 4" (279 mm x 101 mm)		
<b>GEARBOX</b>	SPIRAL GEARS w/ COOLING FINS		
<b>POWER REQUIREMENTS</b>	20 HP - 50 HP (15 kW - 37 kW)	25 HP - 50 HP (18 kW - 37 kW)	30 HP - 50 HP (22 kW - 37 kW)
<b>TRACTOR FIT (HOLDER)</b>	C70 - C270		

# MOWERS

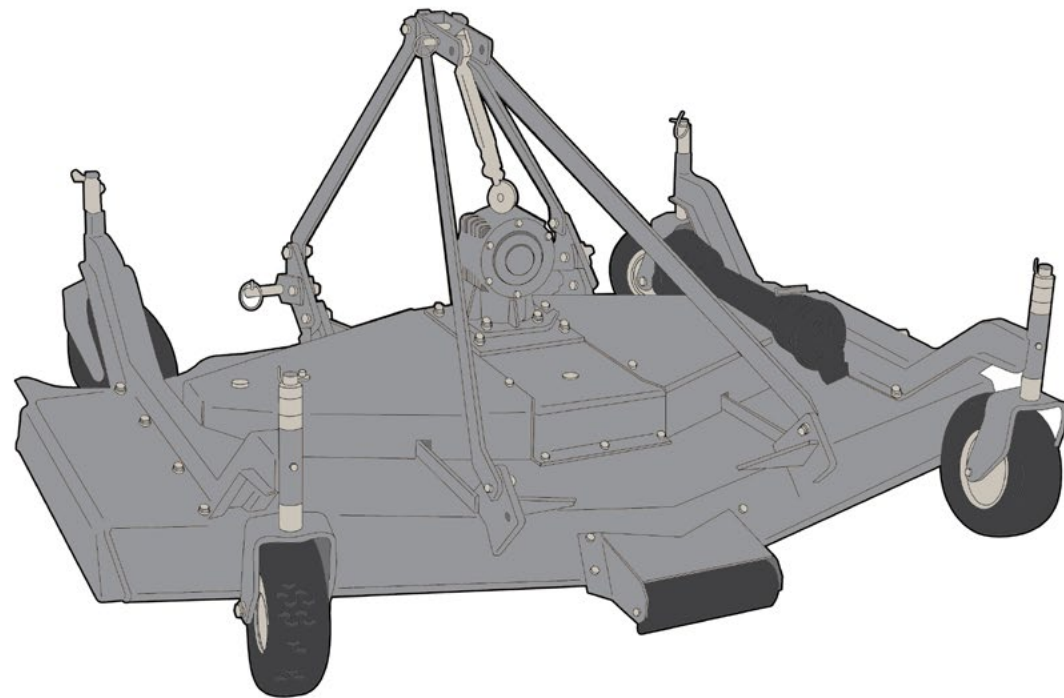

## PTO DRIVEN ROTARY MOWER DECK

MADE IN USA

<b>STANDARD FEATURES</b>	FRONT ANTI-SCALP ROLLER - STAMPED STEEL REINFORCED WHEEL ARMS - MANUAL BELT TENSIONING - DOUBLE BELT TRANSMISSION - FREE SWINGING BLADES - CAST IRON PULLEYS - AXIAL GREASE FITTINGS - 8 GAUGE REINFORCED MOWER DECK - SAFETY CHAIN SHIELD
<b>AVAILABLE OPTIONS</b>	QUICK HITCH ADAPTER - FRONT MOUNT (FACTORY INSTALLED)
<b>TRACTOR REQUIREMENTS</b>	540 RPM - CAT I (3-POINT HITCH) - FRONT AND REAR TRACTOR MOUNTING

MODEL	MRT-090-01	MRT-110-01
<b>WORKING WIDTH</b>	90" (2286 mm)	110" (2794 mm)
<b>OVERALL WIDTH</b>	92" (2336 mm)	112" (2844 mm)
<b>WEIGHT</b>	1137 lb (515 kg)	1290 lb (585 kg)
<b>ROTOR RPM</b>	1750	1562
<b>BLADE TIP SPEED</b>	14,106 ft /min (4299 m /min)	14,998 ft /min (4571 m /min)
<b>NUMBER OF BLADES</b>	6	
<b>CUTTING HEIGHT</b>	1.3" - 5.3" (33 mm - 134 mm)	
<b>NUMBER OF BELTS &amp; TYPE</b>	2 CX	
<b>DRIVELINE 1 3/8"</b>	ASAE CAT 4	
<b>TIRES</b>	PNEUMATIC (4) 13" x 6.5" (330 mm x 165 mm)	
<b>GEARBOX</b>	SPIRAL GEARS w/ COOLING FINES	
<b>POWER REQUIREMENTS</b>	30 HP - 70 HP (22 kW - 52 kW)	40 HP - 70 HP (29 kW - 52 kW)
<b>TRACTOR FIT (HOLDER)</b>	C992 - S75 - S100 - S130	

# MOWERS

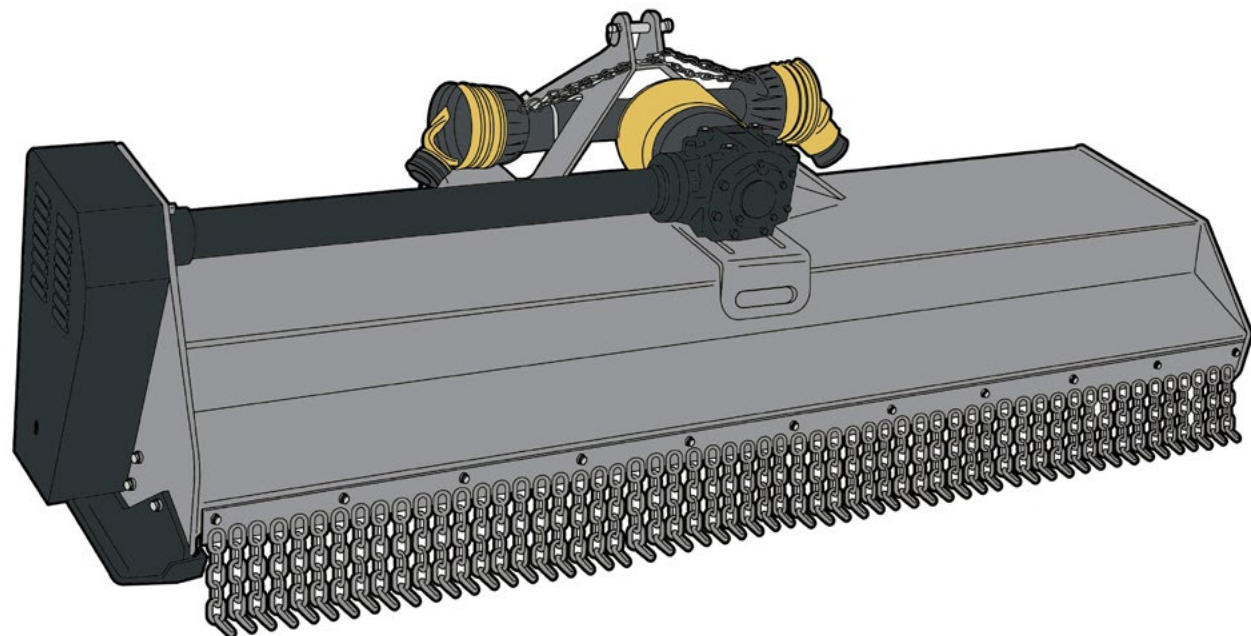

## PTO DRIVEN FLAIL MOWER

MADE IN USA

<b>STANDARD FEATURES</b>	CAST IRON ROTOR SUPPORTS - BELT SHIELD FENDER - REPLACEABLE SIDE SKIDS - CLOCKWISE ROTOR ROTATION
<b>AVAILABLE OPTIONS</b>	GAUGE WHEELS - FRONT MOUNT - REVERSE ROTATION - METAL DUST SKIRT
<b>AVAILABLE BLADE OPTIONS</b>	DETHATCHING - REVERSE "Y" - TRIANGULAR PADDLE - HAMMER (ALL FACTORY INSTALLED)
<b>TRACTOR REQUIREMENTS</b>	540 RPM - CAT I   CAT II (3-POINT HITCH) - FRONT AND REAR TRACTOR MOUNTING

MODEL	MFL-060-01	MFL-072-01	MFL-088-01
<b>WORKING WIDTH</b>	60" (1524 mm)	72" (1829 mm)	88" (2235 mm)
<b>OVERALL WIDTH</b>	71" (1803 mm)	85" (2159 mm)	99" (2515 mm)
<b>WEIGHT</b>	869 lb (394 kg)	955 lb (433 kg)	1078 lb (489 kg)
<b>ROTOR RPM</b>	2080		
<b>BLADE TIP SPEED</b>	8464 ft /min (2579 m /min)		
<b>NUMBER OF BLADES</b>	64	80	96
<b>CUTTING HEIGHT</b>	3/4" x 6" (19 mm - 152 mm)		
<b>NUMBER OF BELTS &amp; TYPE</b>	2 CX		
<b>DRIVELINE 1 3/8"</b>	ASAE CAT 4 OVERRUNNING CLUTCH		
<b>POWER REQUIREMENTS</b>	30 HP - 70 HP (22 kW - 52 kW)	35 HP - 70 HP (26 kW - 52 kW)	40 HP - 70 HP (30 kW - 52 kW)
<b>TRACTOR FIT (HOLDER)</b>	C70 - C270	C70 - C270 - C992 - S75 - S100 - S130	S100 - S130

# MOWERS

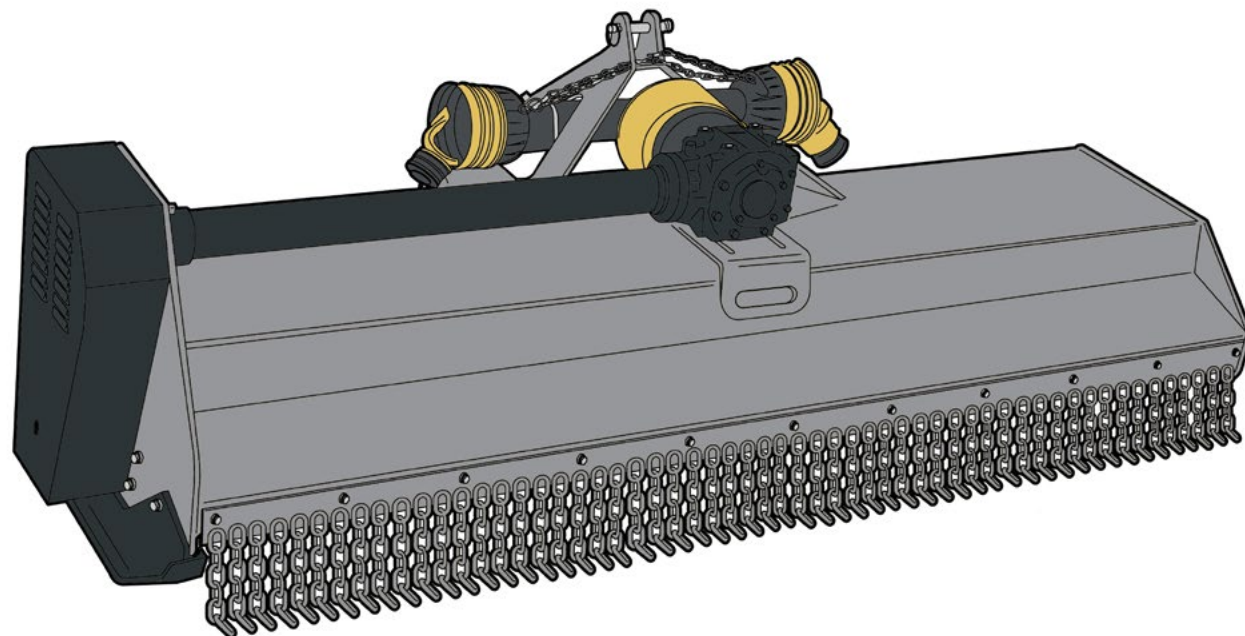

## PTO DRIVEN FLAIL MOWER

MADE IN USA

<b>STANDARD FEATURES</b>	HEAVY DUTY BELT DRIVEN TRANSMISSION - HEIGHT ADJUSTMENT ROLLER - REVERSIBLE "A" FRAME - CLOCKWISE ROTOR ROTATION - CAST IRON ROTOR SUPPORTS - HYDRAULIC OFFSET CYLINDER
<b>AVAILABLE OPTIONS</b>	SIDE SKIDS - FRONT MOUNT (FACTORY INSTALLED) - GEARBOX W/ DUAL PTO (FACTORY INSTALLED)
<b>TRACTOR REQUIREMENTS</b>	540 RPM - CAT I   CAT II (3-POINT HITCH) - FRONT AND REAR TRACTOR MOUNTING

MODEL	MFL-060-03	MFL-072-03
<b>WORKING WIDTH</b>	60" (1524 mm)	72" (1829 mm)
<b>OVERALL WIDTH</b>	69" (1752 mm)	81" (2057 mm)
<b>WEIGHT</b>	1257 lb (570 kg)	1345 lb (610 kg)
<b>ROTOR RPM</b>	1961	
<b>BLADE TIP SPEED</b>	8268 ft/ min (2520 m /min)	
<b>NUMBER OF HAMMERS</b>	16	20
<b>CUTTING HEIGHT</b>	3/4" x 5" (19 mm - 127 mm)	
<b>NUMBER OF BELTS &amp; TYPE</b>	4 XPBX	
<b>DRIVELINE 1 3/8"</b>	ASAE CAT 6 OVERRUNNING CLUTCH	
<b>HYDRAULIC SIDE-SHIFT</b>	12" (304 mm)	16" (406 mm)
<b>POWER REQUIREMENTS</b>	40 HP - 80 HP (30 kW - 60 kW)	50 HP - 90 HP (37 kW - 67 kW)
<b>TRACTOR FIT (HOLDER)</b>	S75 - S100 - S130	C992 - S75 - S100 - S130

# WATER TANKS

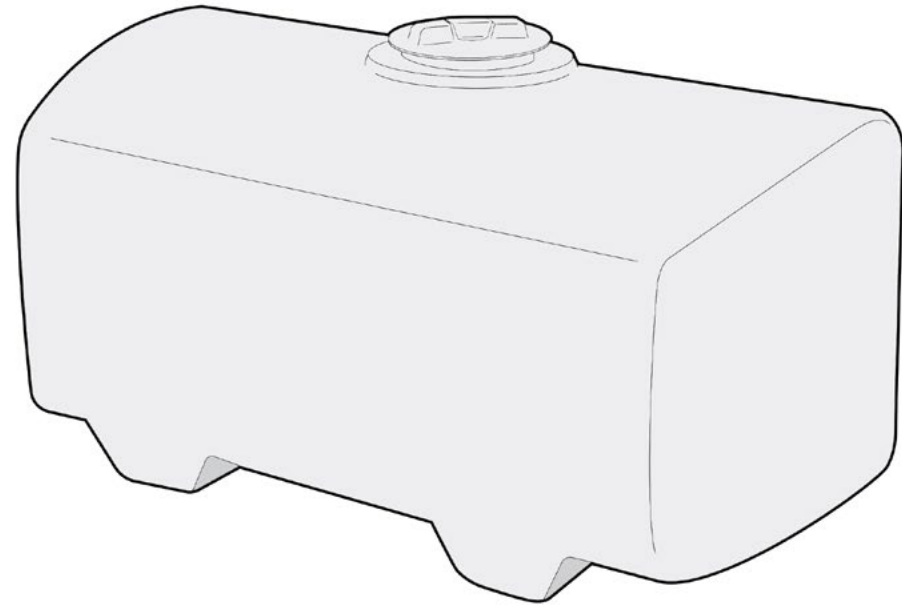

MADE IN CANADA

## WATER TANK (WITHOUT BAFFLES)

<b>STANDARD FEATURES</b>	HOSE CONNECTIONS
<b>MOUNTING OPTIONS</b>	IN THE DUMP BODY (FRAME REQUIRED) ON THE PLATFORM (FRAME REQUIRED)
<b>FRAME OPTIONS</b>	WTF-100-01 (DUMP BODY MOUNT) WTF-100-02 (PLATFORM MOUNT)
<b>TRACTOR REQUIREMENTS</b>	OVER-ENGINE PLATFORM OR IN THE DUMP BODY

MODEL	WTA-100-01	WTA-150-01
<b>TOTAL VOLUME</b>	100 gal (440 L)	150 gal (568 L)
<b>LENGTH</b>	38" (965 mm)	48" (1219 mm)
<b>WIDTH</b>	30" (762 mm)	36" (914 mm)
<b>HEIGHT</b>	28" (711 mm)	
<b>MATERIAL</b>	POLYETHYLENE	
<b>TRACTOR FIT (HOLDER)</b>	C70 - C270	C992 - S75 - S100 - S130

# WATER TANKS

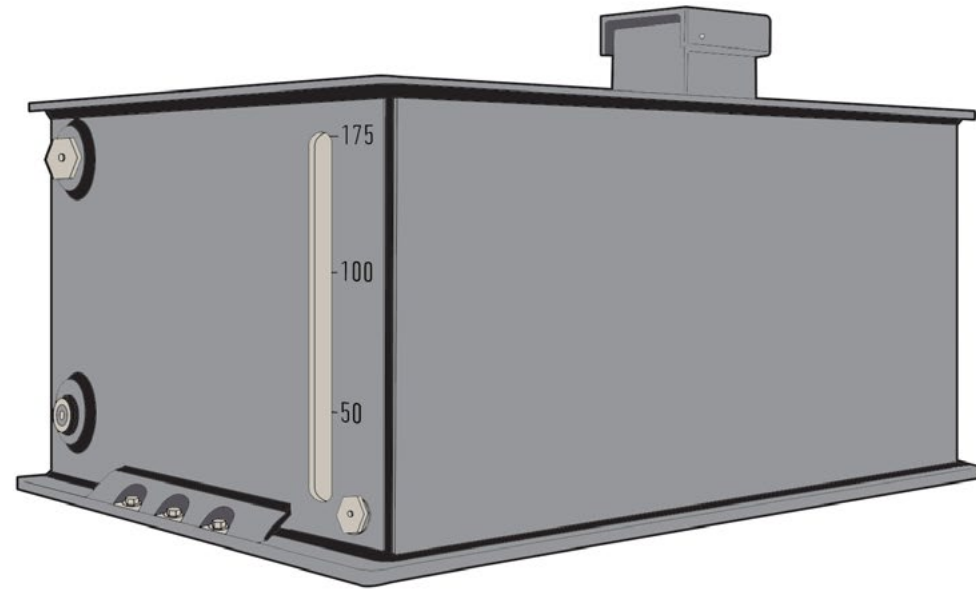

## WATER TANK (WITH BAFFLES)

MADE IN CANADA

<b>STANDARD FEATURES</b>	HOSE CONNECTIONS - PLATFORM MOUNT
<b>MOUNTING OPTIONS</b>	ON THE PLATFORM ONLY
<b>TRACTOR REQUIREMENTS</b>	OVER-ENGINE PLATFORM

MODEL	WTA-175-01	WTA-250-01
<b>TOTAL VOLUME</b>	175 gal (771 L)	250 gal (946 L)
<b>LENGTH</b>	52" (1321 mm)	64" (1626 mm)
<b>WIDTH</b>	40" (1016 mm)	46" (1168 mm)
<b>HEIGHT</b>	25" (635 mm)	32.5" (825 mm)
<b>MATERIAL</b>	POLYETHYLENE	
<b>TRACTOR FIT (HOLDER)</b>	C70 - C270	C992 - S75 - S100 - S130

# SPRAY BARS

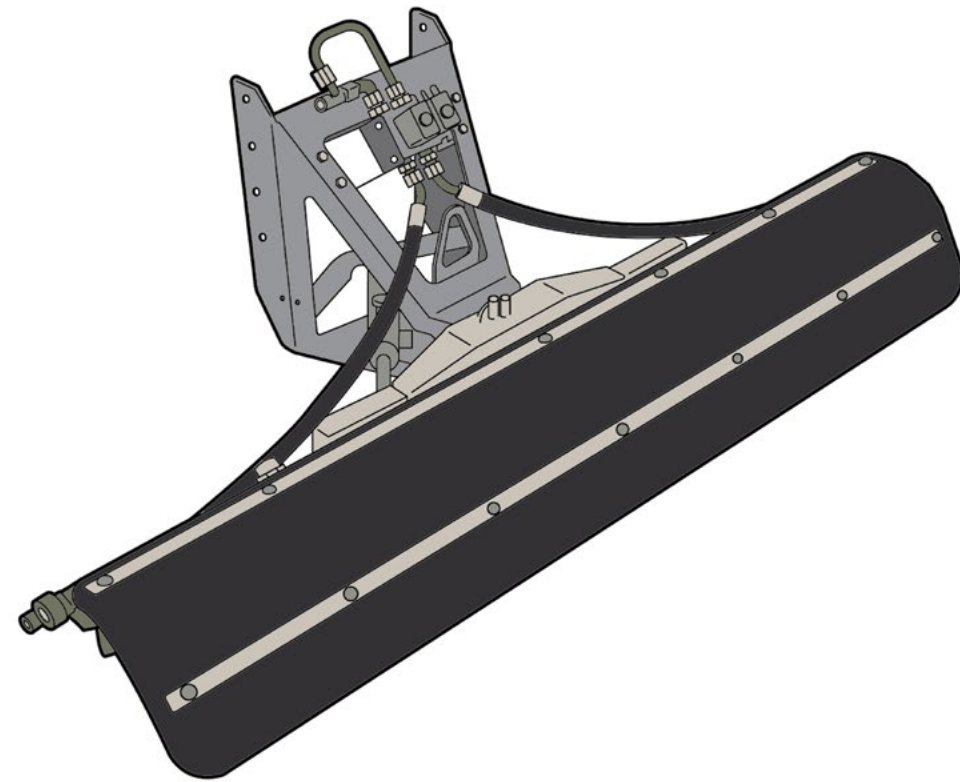

## HYDRAULIC SWIVELING FRONT SPRAY BAR

MADE IN EU

<b>STANDARD FEATURES</b>	HYDRAULIC ANGLING (L/R) - MANUAL HEIGHT ADJUSTMENT - FRONT ADAPTER PLATE HOLDER C250-C270-C480-C992 - FLAT-FACE COUPLINGS - SUPPORT LEG
<b>AVAILABLE OPTIONS</b>	SPRAY GUARD - SIDE NOZZLES - 20" (500 mm) L/R TELESCOPIC EXTENSION
<b>TRACTOR REQUIREMENTS</b>	CAT I (3 POINT HITCH) - 1 SET OF HYDRAULIC QUICK COUPLINGS (DOUBLE ACTING)
<b>OTHER REQUIREMENTS</b>	WATER TANK SYSTEM <b>WTS-171-02</b> OR <b>WTS-171-03</b>

MODEL	SPB-059-01	SPB-070-01
<b>TOTAL WIDTH</b>	59" (1500 mm)	70" (1778 mm)
<b>WORKING WIDTH 30°</b>	51" (1300 mm)	62" (1574 mm)
<b>LENGTH</b>	(19.6") 550 mm	
<b>HEIGHT</b>	(15.7") 400 mm	
<b>WEIGHT</b>	154 lb (70 kg)	165 lb (75 kg)
<b>BAR MATERIAL</b>	STAINLESS STEEL	
<b>POWER REQUIREMENTS</b>	3.9 gpm (15 L /min)	
<b>WATER PRESSURE</b>	725 psi @ 21 gal (50 bar @ 80 L) (w/ MEDIUM PRESSURE PUMP)	1883 psi @ 21 gal (130 bar @ 80 L) (w/ HIGH PRESSURE PUMP)
<b>TRACTOR FIT (HOLDER)</b>	C70 - C270	C70 - C270 - C992 - S75 - S100 - S130

# WATERING ARM

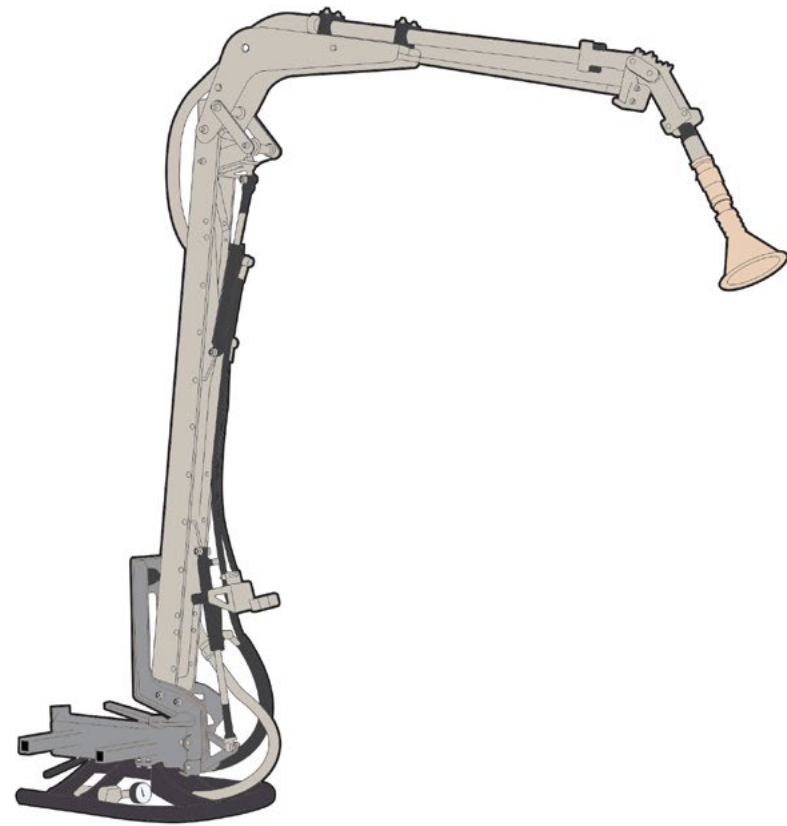

## HYDRAULIC WATERING ARM

MADE IN EU

<b>STANDARD FEATURES</b>	ADAPTER PLATE HOLDER C250-C270-C480-C992 - FLAT SEALING COUPLINGS - ELECTRICAL ANGLING OF THE SPRAYING HEAD - STANDARD HOLDER JOYSTICK CONTROLS
<b>AVAILABLE OPTIONS</b>	FMC MULTIMATIC CONTROL BOX W/ JOYSTICK ( <b>WAR-161-02</b> )
<b>TRACTOR REQUIREMENTS</b>	CAT I   CAT II (3-POINT HITCH) - 2 SETS OF HYDRAULIC QUICK COUPLERS (DOUBLE ACTING)
<b>OTHER REQUIREMENTS</b>	WATER TANK SYSTEM <b>WTS-171-01</b> OR <b>WTS-171-02</b>

MODEL	WAR-161-01
<b>WORKING HEIGHT</b>	161" (4100 mm)
<b>SWIVEL RANGE (L/R)</b>	250° (125° L/R) MAIN ARM: 55° TILT - SECONDARY ARM: 150° SWIVEL
<b>SPRAYING HEAD ANGLING</b>	170° ELECTRICALLY ADJUSTABLE
<b>MATERIAL (BOTH ARMS)</b>	STAINLESS STEEL
<b>POWER REQUIREMENTS</b>	13 gpm (51 L /min)
<b>TRACTOR FIT (HOLDER)</b>	C270 - C70 - C992 - S75 - S100 - S130

# POWER ARMS

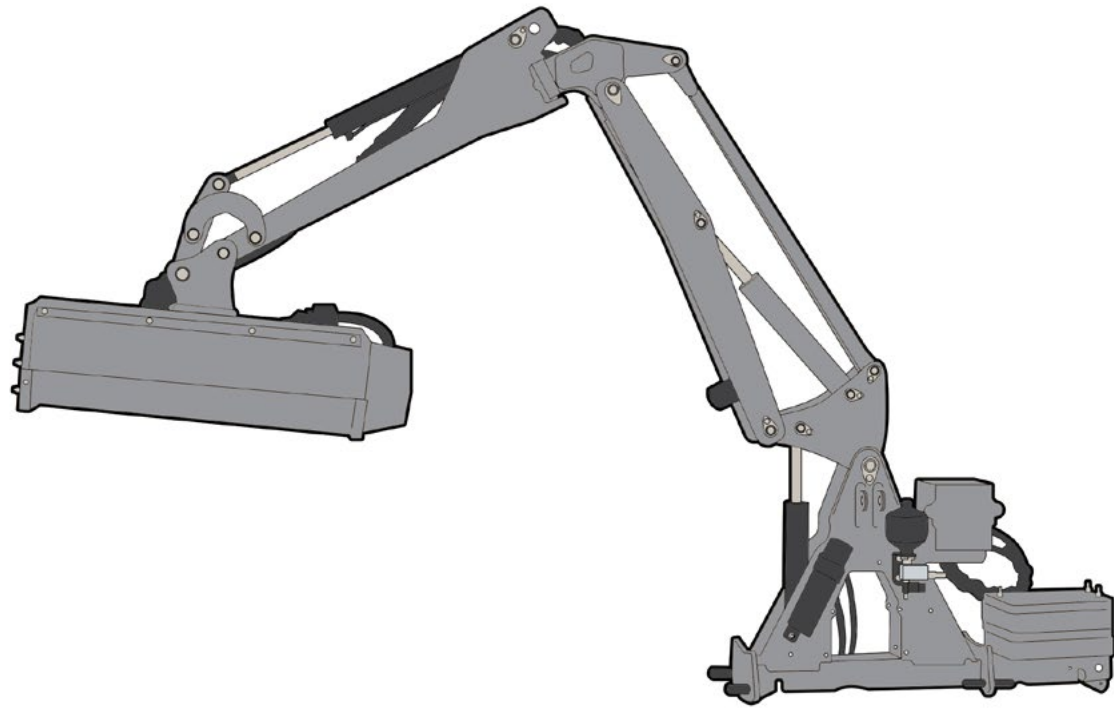

## MULTI-PURPOSE HYDRAULIC POWER ARM (BOOM ARM)

MADE IN EU / UK

<b>STANDARD FEATURES</b>	HYDRAULIC WEIGHT TRANSFER - FLAT SEALING COUPLINGS - HYDRAULIC ANTI-CRASH PROTECTION - HOLDER MOUNTING GROUP - QUICK CHANGE SYSTEM FOR WORKING TOOLS
<b>AVAILABLE OPTIONS</b>	FMC MULTIMATIC CONTROL BOX w/ DIGITAL MOUSE
<b>POWER ARM</b>	DOES NOT INCLUDE HEAD
<b>TRACTOR REQUIREMENTS</b>	COUNTERWEIGHT

MODEL	PAR-157-01	PAR-157-02	PAR-157-03
<b>REACH FROM TRACTOR CENTER</b>	157" (3988 mm)		
<b>OPERATION</b>	HYDRAULIC - HI FLOW		1000 RPM - PTO DRIVEN
<b>WEIGHT</b>	approx. 639 lb (290 kg)		
<b>POWER REQUIREMENTS</b>	3.96 gpm @ 2900 psi (15 L /min @ 200 bar)		
<b>TRACTOR FIT (HOLDER)</b>	C992 - S75 - S100 - S130	C70 - C270	C992 - S75 - S100 - S130
MODEL	PAR-320-01		
<b>REACH FROM TRACTOR CENTER</b>	128" (3251 mm)		
<b>OPERATION</b>	HYDRAULIC		
<b>WEIGHT</b>	1058 lb (480 kg)		
<b>POWER REQUIREMENTS</b>	30 HP (22 kW)		
<b>OIL TANK CAPACITY</b>	16 gal (62 L)		
<b>TRACTOR FIT (HOLDER)</b>	C270 - C70 - C992 - S75 - S100 - S130		

# SPECIAL APPLICATIONS

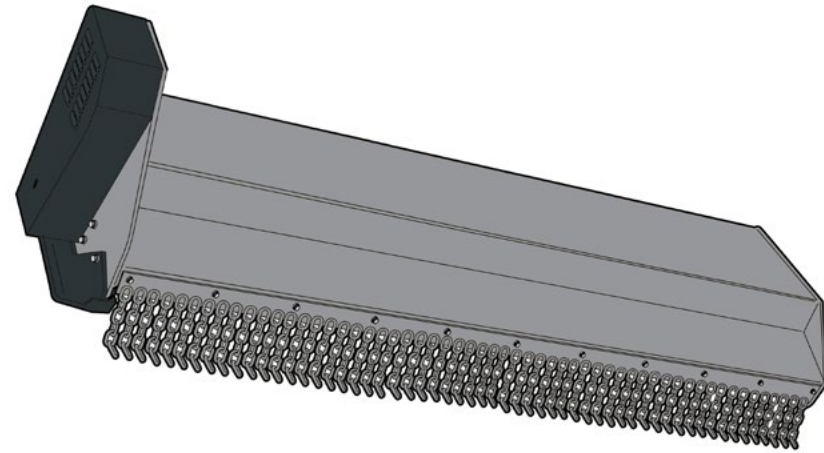

## FLAIL HEAD

MADE IN EU

<b>STANDARD FEATURES</b>	QUICK CHANGE SYSTEM - DIRECT DRIVE VIA AXIAL PISTON ENGINE - SUPPORT ROLLER FOR CUTTING HEIGHT REGULATION - DOUBLE STONE GUARD AT THE FRONT (PLASTIC BAFFLE PLATES & CHAIN GUARD) - SIMPLE IMPACT PROTECTION AT THE BACK (RUBBER APRON)
<b>TRACTOR REQUIREMENTS</b>	MULTI-PURPOSE HYDRAULIC POWER ARM (BOOM ARM) <b>PAR-157-XX</b>

MODEL	HMF-039-02
GRASS TRIM HEIGHT	CUT UP TO Ø 0.78" (20 mm)
WORKING WIDTH	31.5" (800 mm)
NUMBER OF BLADES	32 Y-BLADES
WEIGHT	approx. 363 lb (165 kg)

# SPECIAL APPLICATIONS

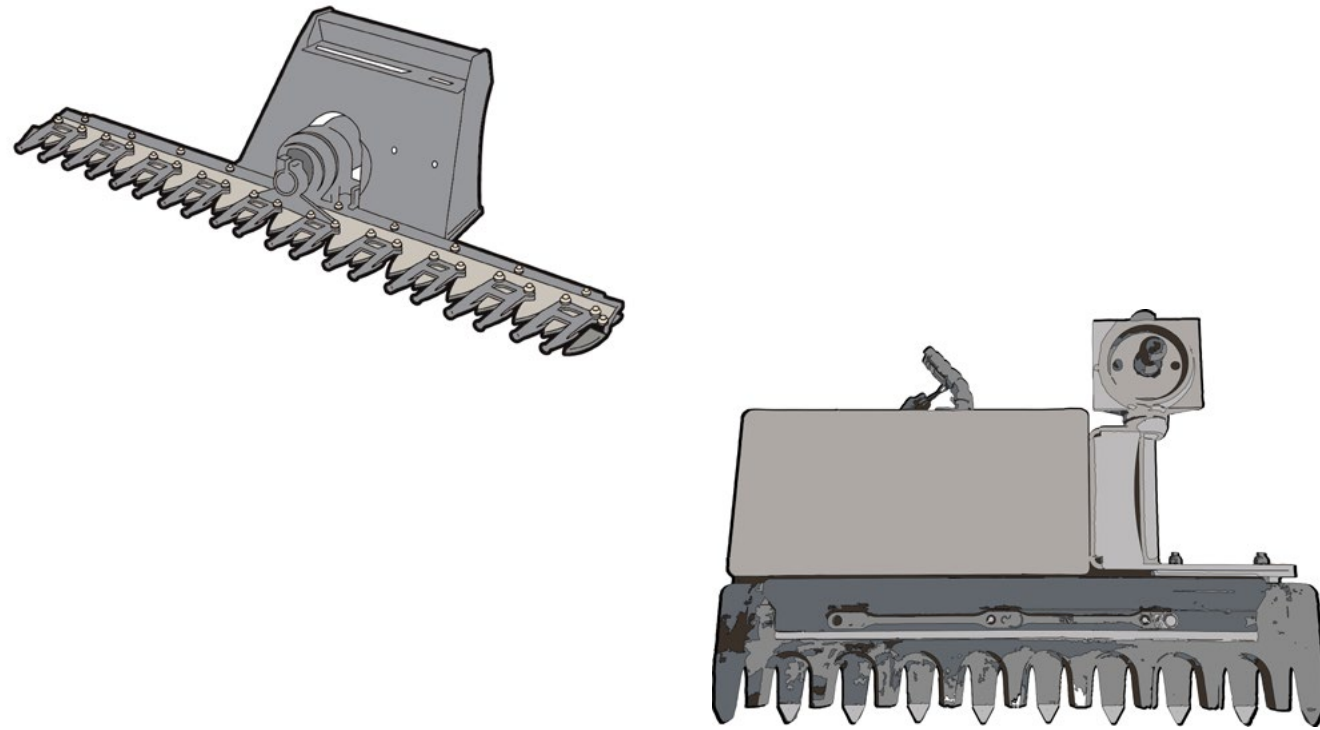

## BRANCH CUTTERS

MADE IN UK / EU

<b>STANDARD FEATURES</b>	QUICK CHANGE SYSTEM
<b>AVAILABLE OPTIONS</b>	<i>ADDITIONAL SIZES AVAILABLE</i>
<b>TRACTOR REQUIREMENTS</b>	MULTI-PURPOSE HYDRAULIC POWER ARM (BOOM ARM) <b>PAR-320-01 &amp; PAR-157-XX</b>

MODEL	BCH-059-01
<b>CUTTING WIDTH</b>	4'9" (1.5 m)
<b>NUMBER OF BLADES</b>	19
<b>STROKES PER MINUTE</b>	60
<b>CUTTING CAPACITY</b>	1.57" (40 mm)
<b>MINIMUM FLOW</b>	13.2 gpm (50 L /min)
<b>PRESSURE</b>	2611 psi (180 bar)
MODEL	BCH-053-01
<b>CUTTING WIDTH</b>	4.42' (1347 mm)
<b>CUTTABLE BRANCH SIZE</b>	max. 3.93' (1197 mm)
<b>STROKES PER MINUTE</b>	100
<b>WEIGHT</b>	410 lb (186 kg)

# SPECIAL APPLICATIONS

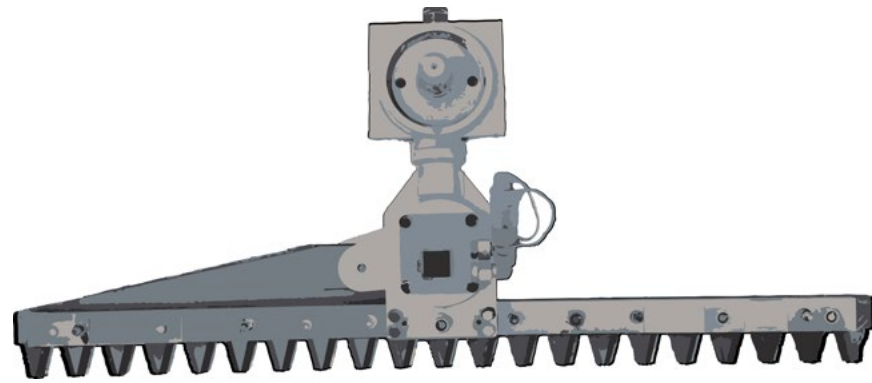
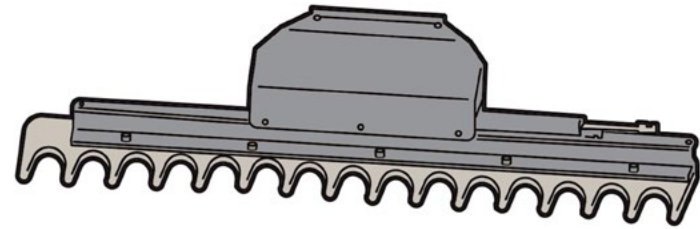

## HEDGE TRIMMERS

MADE IN UK / EU

<b>STANDARD FEATURES</b>	QUICK CHANGE SYSTEM
<b>AVAILABLE OPTIONS</b>	<i>ADDITIONAL SIZES AVAILABLE</i>
<b>TRACTOR REQUIREMENTS</b>	MULTI-PURPOSE HYDRAULIC POWER ARM (BOOM ARM) <b>PAR-320-01 &amp; PAR-157-XX</b>

MODEL	HCH-067-01
<b>CUTTING WIDTH</b>	5'6" (1.7 m)
<b>NUMBER OF BLADES</b>	26
<b>STROKES PER MINUTE</b>	60
<b>CUTTING CAPACITY</b>	3.94" (100 mm)
<b>MINIMUM FLOW</b>	13.2 gpm (50 L /min)
<b>PRESSURE</b>	3191 psi (220 bar)
MODEL	HCH-059-01
<b>CUTTING WIDTH</b>	4.9' (1493 mm)
<b>CUTTABLE BRANCH SIZE</b>	1.57" (40 mm)
<b>STROKES PER MINUTE</b>	36
<b>WEIGHT</b>	216 lb (98 kg)
<b>SPEED CRANK MECHANISM</b>	500 min-1
<b>CAPACITY</b>	14 HP (11 kW)

# SPECIAL APPLICATIONS

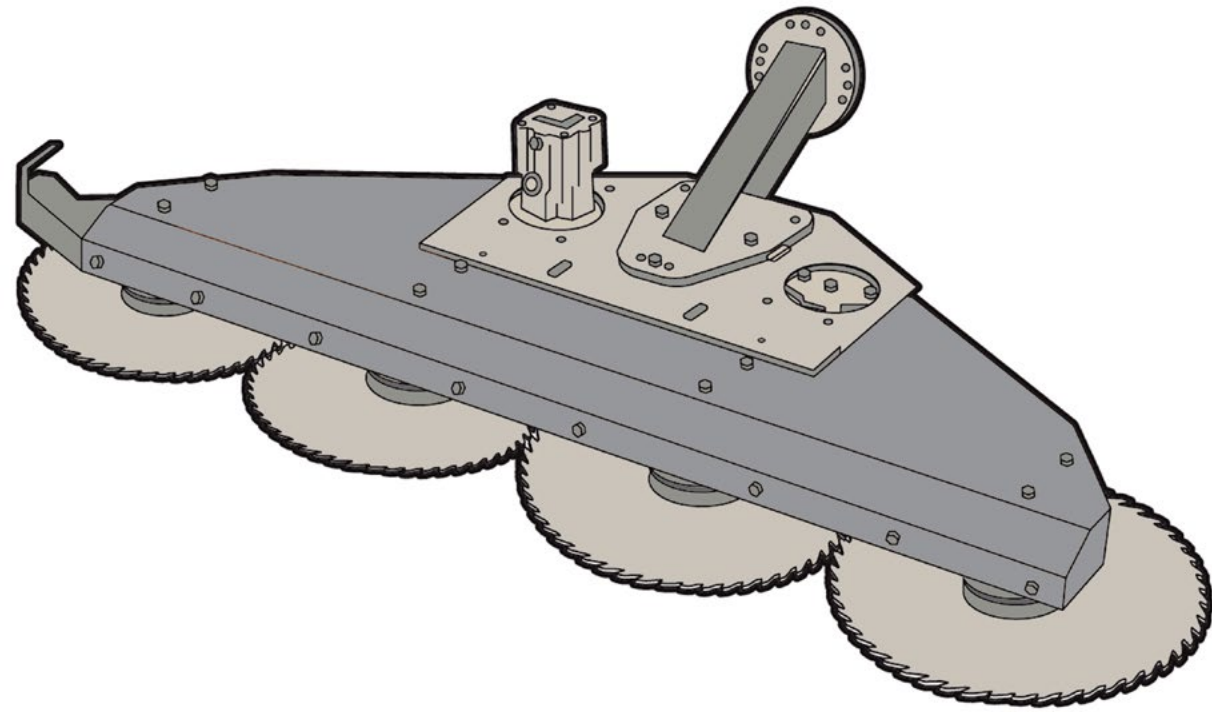

## QUADSAW

MADE IN UK

<b>STANDARD FEATURES</b>	LOW NOISE LEVELS - HIGH SPEED BELT DRIVE - TUNGSTEN CARBIDE TIPPED BLADES
<b>AVAILABLE OPTIONS</b>	MANUAL QUICK RELEASE KIT - HYDRAULIC QUICK RELEASE KIT - <i>TRISAW ALSO AVAILABLE - (3 CIRCULAR SAW BLADES)</i>
<b>TRACTOR REQUIREMENTS</b>	MULTI-PURPOSE HYDRAULIC POWER ARM (BOOM ARM) <b>PAR-320-01</b>

MODEL	MSH-058-01
<b>CUTTING WIDTH</b>	6'5" (2 m)
<b>NUMBER OF BLADES</b>	4 CIRCULAR SAW BLADES
<b>CUTTING CAPACITY</b>	5.9" (150 mm)
<b>MINIMUM FLOW</b>	22.19 gpm - 22.98 gpm (84 L /min - 87 L /min)
<b>PRESSURE</b>	3191 psi (220 bar)

# SPECIAL APPLICATIONS

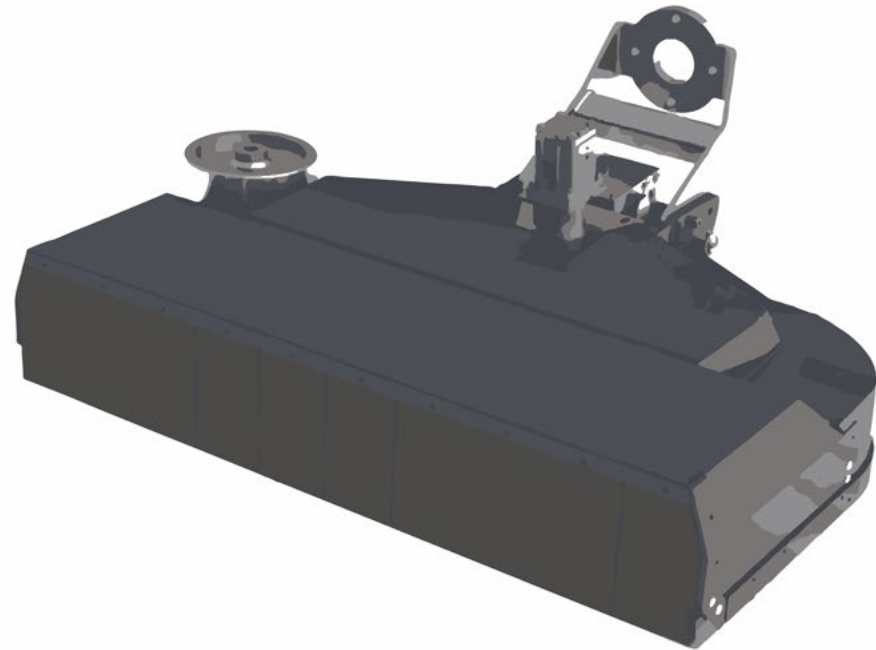

## ROTARY FINISHING HEAD

MADE IN UK

<b>STANDARD FEATURES</b>	BRANCH GUIDE - FRONT RUBBER FLAP - HIGH SPEED BELT DRIVE - (6) BLADE X (3) ROTOR FINE CUT CUTTING SYSTEM
<b>AVAILABLE OPTIONS</b>	MANUAL QUICK RELEASE KIT - HYDRAULIC QUICK RELEASE KIT
<b>TRACTOR REQUIREMENTS</b>	MULTI-PURPOSE HYDRAULIC POWER ARM (BOOM ARM) <b>PAR-320-01</b>

MODEL	MRH-050-01
<b>CUTTING WIDTH</b>	4'2" (1.3 m)
<b>NUMBER OF BLADES</b>	18
<b>CUTTING CAPACITY</b>	1.81" (30 mm)
<b>MINIMUM FLOW</b>	11.88 gpm (45 L /min)
<b>PRESSURE</b>	2610 psi (180 bar)

# SPECIAL APPLICATIONS

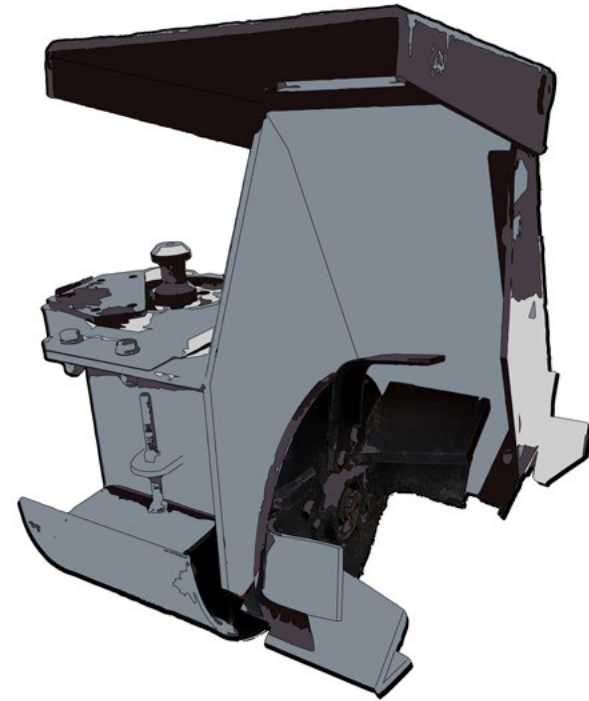

## DITCH DIGGER

MADE IN EU

<b>STANDARD FEATURES</b>	QUICK CHANGE SYSTEM - ADJUSTABLE DISCHARGE CENTER
<b>TRACTOR REQUIREMENTS</b>	MULTI-PURPOSE HYDRAULIC POWER ARM (BOOM ARM) <b>PAR-157-XX</b>

MODEL	DDH-020-01
<b>OIL QUANTITY REQUIRED</b>	15.85 gpm @ 2900 psi (60 L /min @ 200 bar)
<b>CUTTING DISC DIAMETER</b>	19.68" (500 mm)
<b>NUMBER OF BLADES</b>	4
<b>WEIGHT</b>	286 lb (129 kg)

# SPECIAL APPLICATIONS

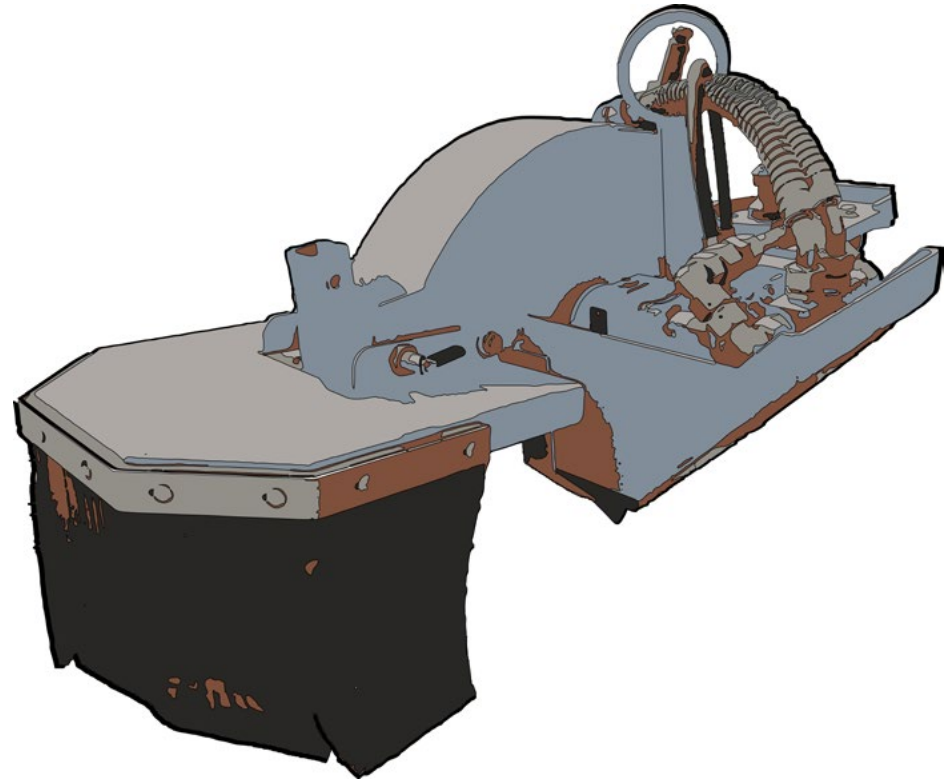

## STUMP GRINDER

MADE IN EU

### STANDARD FEATURES

QUICK CHANGE SYSTEM -  
DRIVE VIA AXIAL PISTON ENGINE -  
ROBUST TRANSMISSION GEAR (w/out CHAIN)

### TRACTOR REQUIREMENTS

MULTI-PURPOSE HYDRAULIC POWER ARM (BOOM ARM)  
**PAR-157-XX**

MODEL	SGH-021-01
MILLING DISC DIAMETER	21.65" (549 mm)
NUMBER OF TEETH	20 CARBIDE TIPS
WORKING DEPTH	15.75" (400 mm)
WEIGHT	132 lb (60 kg)
POWER	33.5 HP (25 kW)
OIL QUANTITY REQUIRED	14.5 gpm @ 2900 psi (55 L /min @ 200 bar)

# SPECIAL APPLICATIONS



## EARTH AUGER

MADE IN EU

### STANDARD FEATURES

QUICK CHANGE SYSTEM -  
w/ ONE PIECE AUGER - EXISTING DRILLS CAN BE USED -  
DRILL CONNECTION STIHL DRILL BT 360

### TRACTOR REQUIREMENTS

MULTI-PURPOSE HYDRAULIC POWER ARM (BOOM ARM)  
**PAR-157-XX**

MODEL	EAH-028-01
DRILLING DEPTH	27" (700 mm)
OIL QUANTITY REQUIRED	15.85 gpm @ 2900 psi (60 L /min @ 200 bar)
DIAMETER	5.9" (150 mm)
WEIGHT	132 lb (60 kg)
SPEED	200 min-1
TORQUE	300 Nm
CAPACITY	14 HP (11 kW)

# SPECIAL APPLICATIONS



## POST BRUSHES

MADE IN EU

### STANDARD FEATURES

QUICK CHANGE SYSTEM -  
 WATER SUPPLY ACTIVATED BY TURNING THE BRUSHES -  
 STAINLESS STEEL SPLASH GUARD MOUNT w/ INTERNAL WATER SUPPLY -  
 WATER HOSES AND COUPLINGS -  
 2 LEVEL ROTATABLE HEAD SETTING ENABLES THE WASHING OF CRASH BARRIERS, REFLECTOR POSTS AND TRAFFIC SIGNS

### TRACTOR REQUIREMENTS

MULTI-PURPOSE HYDRAULIC POWER ARM (BOOM ARM)  
**PAR-157-XX**

MODEL	PWH-019-01
BRUSH DIAMETER	15.74" (400 mm)
BRUSH LENGTH	20.47" (520 mm)
REQUIRED PUMP	4.54 gpm - 6.8 gpm @ 4351 psi (10 L /min - 15 L /min @ 300 bar)
WEIGHT	165 lb (74.84 kg)

# SPECIAL APPLICATIONS

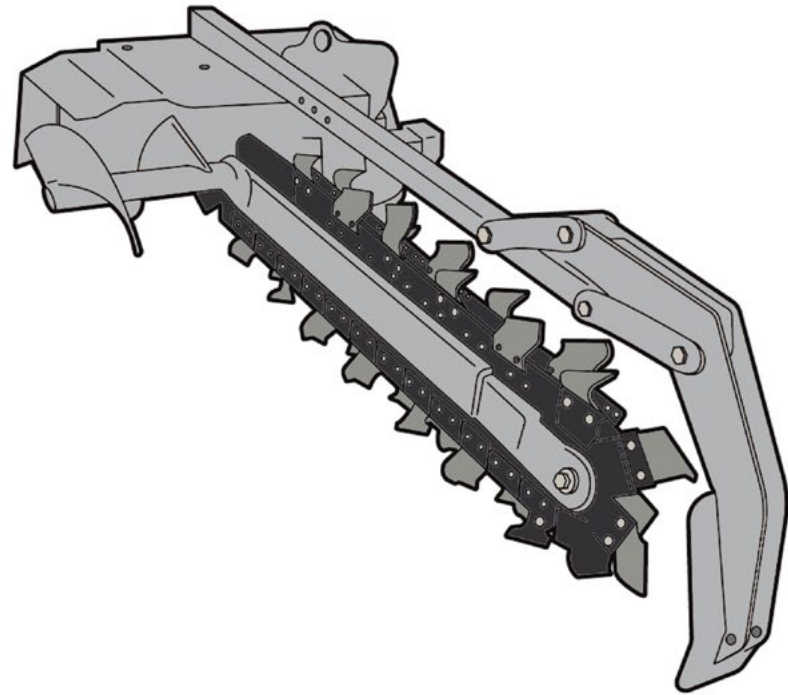

## TRENCH AXE

MADE IN UK

<b>STANDARD FEATURES</b>	SIDE AUGER - HEAVY DUTY SOLID STEEL NOSE - ADJUSTABLE CHAIN TENSION - CRUMB SCRAPER BAR
<b>AVAILABLE OPTIONS</b>	BULLET TOOTH CHAIN
<b>TRACTOR REQUIREMENTS</b>	3-POINT HITCH EXTERNAL CONTROL

MODEL	TRA-036-01
<b>TRENCHER DEPTH</b>	36" (914 mm)
<b>TRENCHER WIDTH</b>	4" - 6" (101 mm - 152 mm)
<b>WEIGHT</b>	810 lb (367 kg)
<b>MAIN SHAFT SIZE</b>	2 - 9/16" SOLID HARDENED STEEL
<b>OVER TORQUE PROTECTION</b>	HYDRAULIC RELIEF
<b>DRIVE TYPE</b>	PLANETARY
<b>POWER REQUIREMENTS</b>	40 HP - 100 HP (30 kW - 74 kW)
<b>TRACTOR FIT (HOLDER)</b>	C992 - S100 - S130

# SPECIAL APPLICATIONS

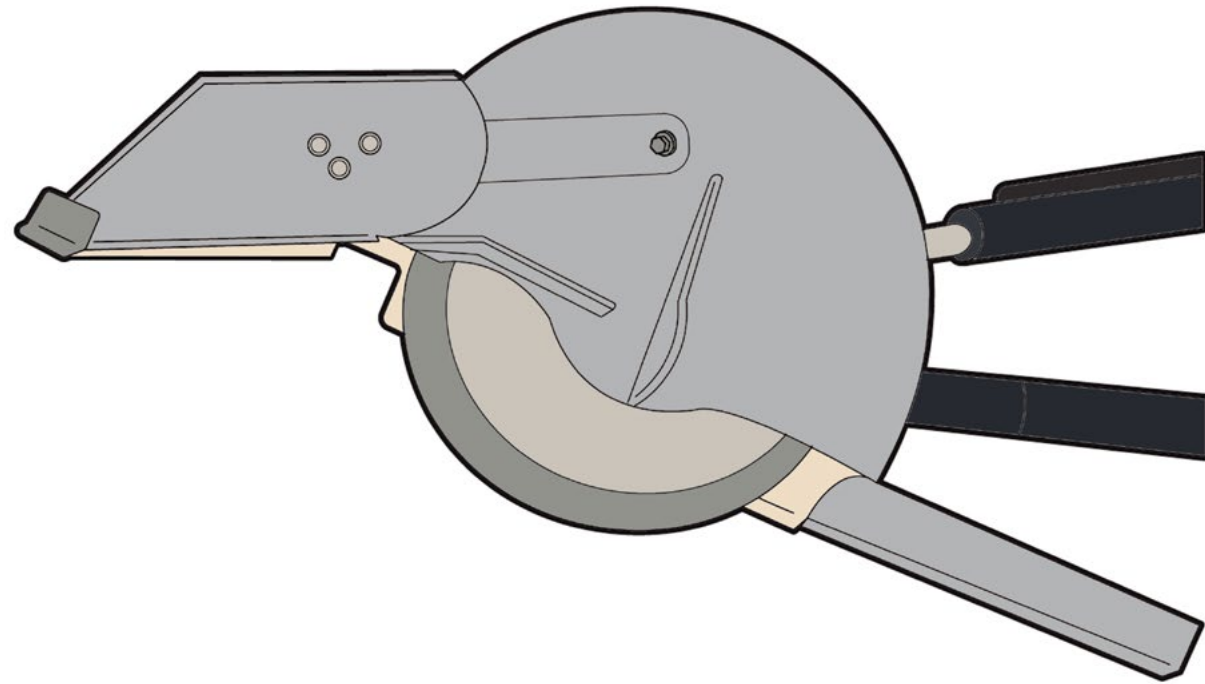

## STUMP GRINDER

MADE IN UK

<b>STANDARD FEATURES</b>	FLOW CONTROL CUTTING PASS SPEED - RUGGED GEARBOX - BOLT-ON TEETH DESIGN - HEAVY DUTY STABILIZER BASE - FLOATING DEFLECTOR
<b>AVAILABLE OPTIONS</b>	EXTERNAL CONTROL
<b>TRACTOR REQUIREMENTS</b>	CAT II (3-POINT HITCH)

MODEL	STG-024-01
LENGTH	49" (1244 mm)
WIDTH	42" (1066 mm)
ROTOR SIZE	24" (609 mm)
NUMBER OF TEETH	34
TOOTH CONSTRUCTION	S1000
CUTTING WHEEL SPEED	810 RPM
CUTTING HEIGHT	18" (457 mm) (ABOVE GROUND)
CUTTING DEPTH	8" (203 mm) (BELOW GROUND)
SWING ARC	65°
WEIGHT	624 lb (283 kg)
MAX. ENGINE HP	65 HP (48 kW)
MAX. PTO HP	55 HP (41 kW)
POWER REQUIREMENTS	25 HP - 55 HP (18 kW - 41 kW)
TRACTOR FIT (HOLDER)	C270 - C70 - C992 - S100 - S130

# SPECIAL APPLICATIONS

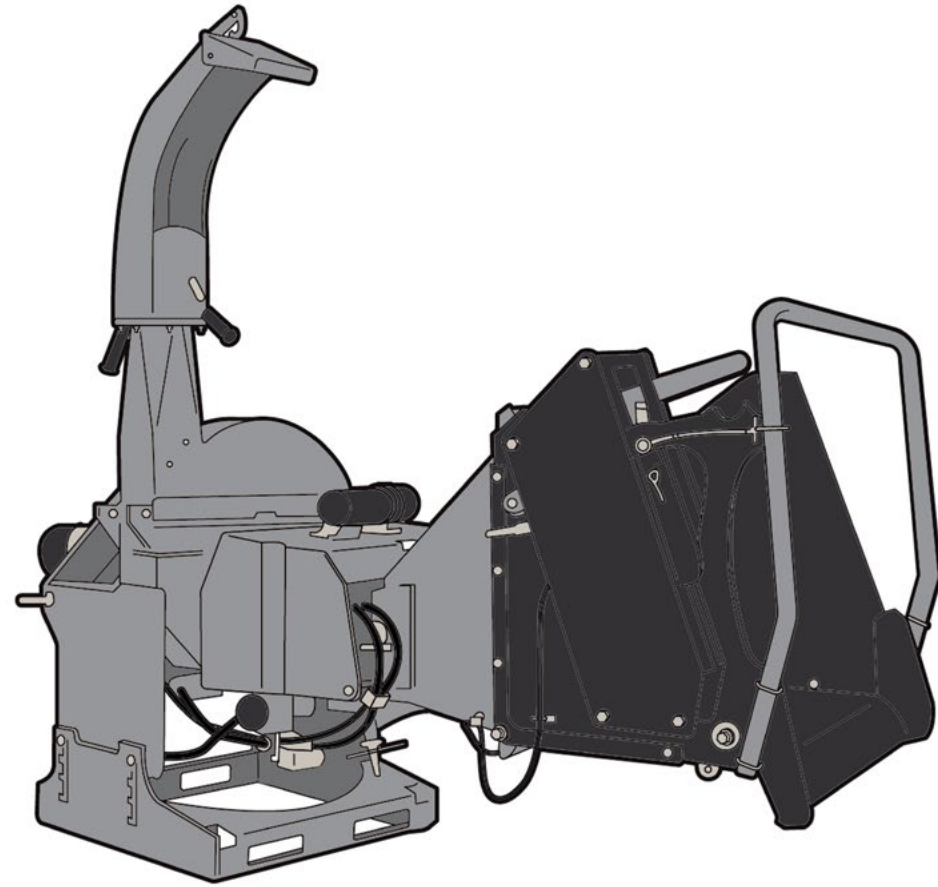

MADE IN CANADA

## WOOD CHIPPER

<b>STANDARD FEATURES</b>	360° ADJUSTABLE CHUTE - ADJUSTABLE SKI BASE - DUAL ACTIVE ROLLERS - FOLD UP FEED HOPPER - SAFETY CONTROL BAR - SHEARBOLT PROTECTED PTO DRIVETRAIN
<b>AVAILABLE OPTIONS</b>	REVERSIBLE ROTOR KNIVES
<b>TRACTOR REQUIREMENTS</b>	CAT II   QUICK HITCH COMPATIBLE

MODEL	WCH-005-01
<b>LENGTH</b>	80" (2032 mm) OPEN 62" (1575 mm) FOLDED
<b>WIDTH</b>	67" (1702 mm) OPEN 61" (1549 mm) FOLDED
<b>HEIGHT</b>	74" (1879 mm) OPEN 74" (1879 mm) FOLDED
<b>CHIPPING CAPACITY</b>	5" (127 mm)
<b>DRIVE SYSTEM</b>	PTO DIRECT DRIVE
<b>WEIGHT</b>	845 lb (383 kg)
<b>CHIPPER TYPE</b>	DISC
<b>FEED SYSTEM</b>	DUAL HYDRAULIC ROLLER FEED
<b>NUMBER OF CHIPPER KNIVES</b>	4
<b>DISCHARGE CHUTE ROTATION</b>	360°
<b>RPM</b>	540 - 1000
<b>HYDRAULIC FLOW</b>	3 gpm - 6 gpm (12 L /min - 23 L /min)
<b>POWER REQUIREMENTS</b>	40 HP - 55 HP (30 kW - 41 kW)
<b>TRACTOR FIT (HOLDER)</b>	C270 - C70 - C992 - S100 - S130

# SPECIAL APPLICATIONS

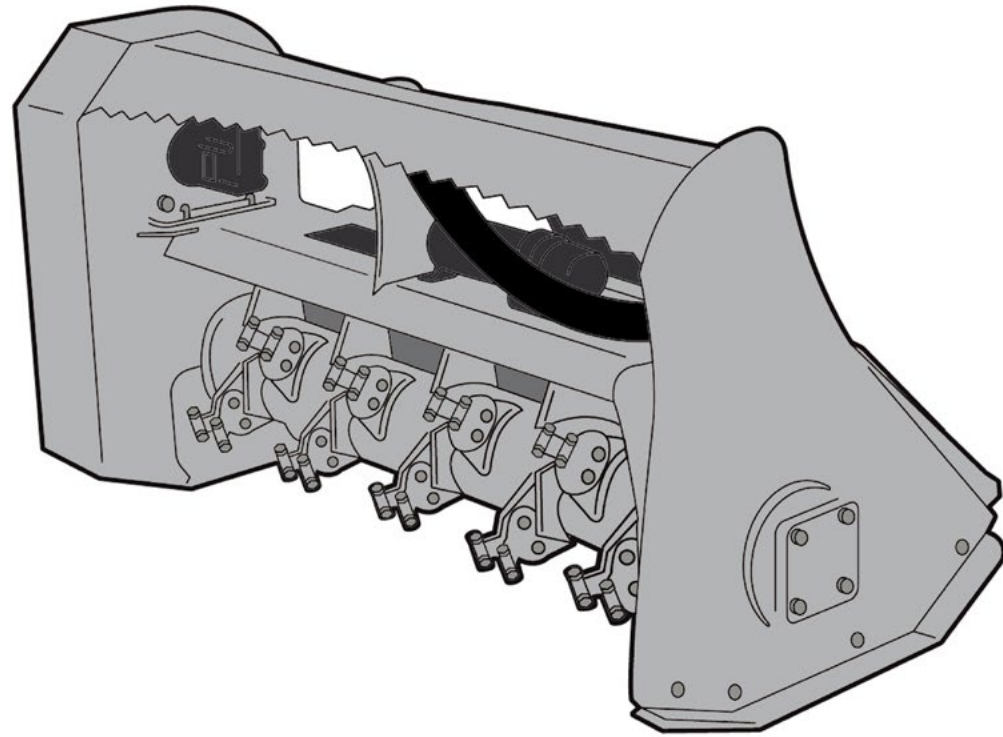

MADE IN CANADA

## HEAVY DUTY MULCHER

<b>STANDARD FEATURES</b>	INTEGRATED BRUSH BAR - INTEGRATED SKID SHOES - HIGH SPEED TEETH - SPIRAL TOOTH PATTERN - HEAVY DUTY GEARBOX - REINFORCED BELT - POWDER COAT WIRE PROTECTION KIT - SLIP CLUTCH PROTECTION
<b>TRACTOR REQUIREMENTS</b>	CAT II (3-POINT HITCH)

MODEL	HDM-060-01
PATH WIDTH	60" (1524 mm)
ROTOR WIDTH	48" (1219 mm)
CUTTING STYLE	HIGH SPEED TEETH
NUMBER OF TEETH	60
ROTOR SHAFT SIZE	2" (51 mm)
ROTOR DIAMETER	15" (381 mm)
WEIGHT	1050 lb (476 kg)
RPM	1800
DRIVE SPEED	540 RPM
POWER REQUIREMENTS	25 HP - 50 HP (18 kW - 37 kW)
TRACTOR FIT (HOLDER)	C992 - S100 - S130

# SPECIAL APPLICATIONS

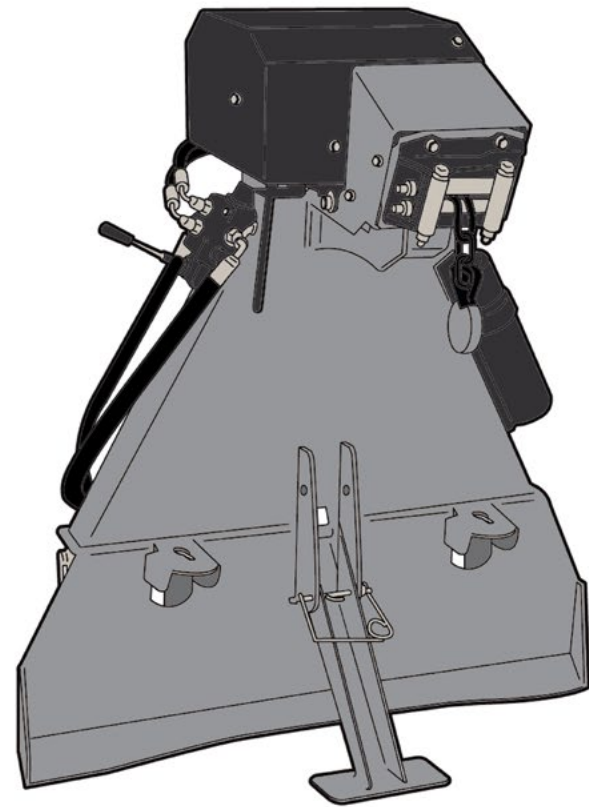

MADE IN CANADA

## SKIDDING WINCH

<b>STANDARD FEATURES</b>	2 CHOKER CHAINS - 2 KEY HOLE SLIDERS - TOW BAR - TRAILER HITCH - REMOVABLE CLUTCH ASSEMBLY - SNATCH BLOCK PULLEY SYSTEM - ROPE CONTROLLED BRAKE/CLUTCH SYSTEM - SHEARBOLT PROTECTED PTO DRIVETRAIN
<b>AVAILABLE OPTIONS</b>	60" (1524 mm) or 84" (2133 mm) SYNTHETIC CHOKER - 90" (2286 mm) CHOKER CHAIN - LOGGING TONGS - NYLON CHAINSAW HOLDER - SELF-RELEASING DIRECTIONAL PULLEY - SYNTHETIC ROPE
<b>TRACTOR REQUIREMENTS</b>	CAT I   CAT II

MODEL	SKW-080-01
LENGTH	28" (711 mm)
WIDTH	51" (1295 mm)
HEIGHT	79" (2006 mm)
PULLING CAPACITY	11,000 lb (4989 kg)
WINCH TYPE	MECHANICAL DRY DISC CLUTCH
LINE SPEED	98 ft-min - 253 ft-min (30 m /min - 77 m /min)
CABLE TYPE	STEEL
CABLE LENGTH	165' (50 m)
CABLE DIAMETER	7/16" (11 mm)
CHOKER CHAINS	2
PTO INPUT SPEED	540 RPM
WEIGHT	796 lb (361 kg)
POWER REQUIREMENTS	50 HP - 90 HP (37 kW - 67 kW)
TRACTOR FIT (HOLDER)	C270 - C70 - C992 - S100 - S130

# SPECIAL APPLICATIONS

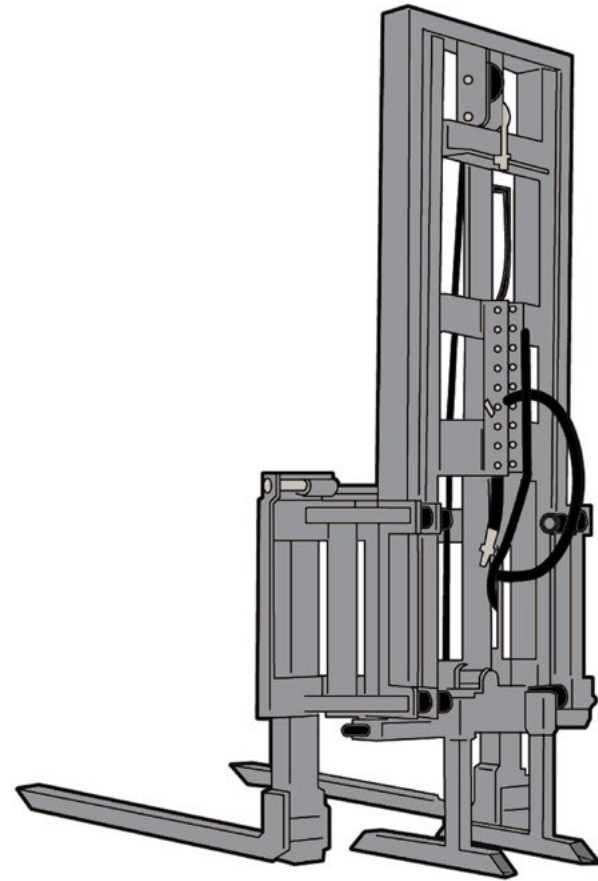

MADE IN CANADA

## FORK LIFT

<b>STANDARD FEATURES</b>	EQUIPPED w/ FOLDING LINES
<b>AVAILABLE OPTIONS</b>	60" (1524 mm) HOSE KITS w/ PIONEER COUPLINGS
<b>TRACTOR REQUIREMENTS</b>	2 SETS OF HYDRAULIC QUICK COUPLERS (DOUBLE ACTING) - CAT II

MODEL	FKL-059-01
<b>LIFT CAPACITY</b>	3500 lb (1587 kg)
<b>LIFT HEIGHT</b>	59" (1498 mm)
<b>RETRACTED HEIGHT</b>	65" (1651 mm)
<b>TRACTOR FIT (HOLDER)</b>	S75 - S100 - S130